

National Park Service
U.S. Department of the Interior



Capulin Volcano National Monument
46 Volcano
Capulin, NM 88414

A proposal to:

The International Dark Sky Association

3225 North First Ave.
Tuscon, AZ 85719

National Park Service
U.S. Department of the Interior

Capulin Volcano National Monument



International Dark-Sky Park Application

Capulin Volcano National Monument

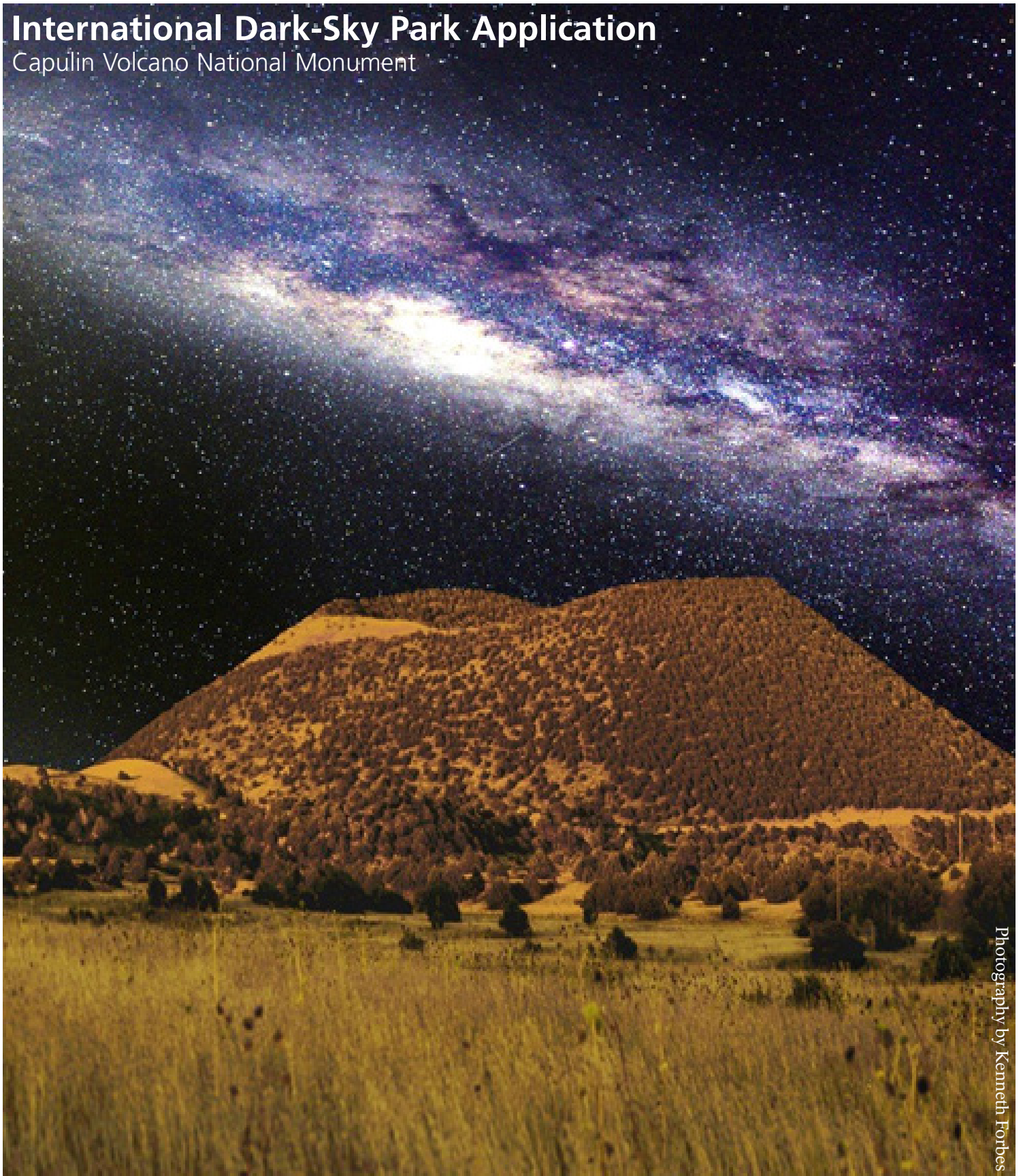

Photography by Kenneth Forbes

Contents

Introduction 04

Purpose and Significance 04
Elevation 04
Visibility 05
Weather and Climate 05
Surrounding Communities 06
Population Density
Light Barriers

Dark Sky Park Status 09

Dark Sky Commitment 09
Existing Conditions 10
Measurements and Assessments 10
Clayton vs. Capulin 15
Ongoing Monitoring and Data Collection 15

Lighting Inventory and Management 17

Summary 18
Visitor Center 19
Employee Housing 21

Interpretation and Education 24

Current Efforts 24
Restoration Leadership 25
Social Media 25
Park Store 26

Capulin Guidelines 27

Human Lighting Needs 27
Human and Environmental Health 27
Long Eared Bats 28
Selecting and Evaluating 28
Energy and Efficiency 28
Costs 29

Outdoor Lighting Zones 30

Minimal Lighting Zone
No Lighting Zone

Night Sky Related Management Documents 31

Measuring Lightscapes
NPS Management Policies 2006
NPS interim Outdoor Lighting Guidelines
New Mexico Night Sky Protection Act

Letters of Support 56

Works Cited 57



Introduction

Capulin Volcano National Monument (CAVO) was established as a unit of the National Park Service by presidential proclamation on August 9, 1916. President Woodrow Wilson declared Capulin Mountain a national monument to preserve “A striking example of recent extinct volcanoes... of great scientific and especially geologic interest” (Presidential Proclamation No. 1340 [39 Stat. 1792]).

Located in northeastern New Mexico, Capulin Volcano is centralized approximately 55 miles east of Clayton and 35 miles west of Raton. The primary feature of the monument is the cinder cone. The well-preserved, and young symmetrical volcanic feature rises steeply and conspicuously from the surrounding grassland plains to an elevation of 8,182 feet above sea level. It is just one of approximately 120 volcanic features that can be found in the Raton-Clayton Volcanic Field (RCVF), which spans over 8,000 square miles encompassing a landmass roughly the size of the state of Massachusetts. The volcanoes of the RCVF comprise the easternmost Cenozoic volcanic range in North America dating 9 million years ago. Scientists agree that the field is considered dormant, and the last activity occurred approximately 11,000 years ago in the northern range of the field located in southern Colorado. The eruption of Capulin Volcano is one of the most recent eruptions occurring as recently as 53,000 years ago. The lava flows associated with Capulin span an area of more than 15 square miles extending far beyond the 793 acres dedicated towards the monument.

Purpose and National Significance

The purpose of Capulin Volcano National Monument is to preserve, protect, and interpret the scientific values, geologic integrity, and scenic viewshed of the striking volcanic features resulting for the creation and eruption of Capulin Volcano. Significance statements similarly express why federal public resources and values are important enough to merit national park unit designation. These statements are linked to the purpose of the park unit, and are supported by data, research, and consensus. Significance statements describe the distinctive nature of the park and inform management decisions, focusing efforts on preserving and protecting the most important resources and values of the park unit.

Significance statements for Capulin Volcano are as follows:

- Capulin Volcano’s classic cinder cone and associated volcanic features provide a striking example of a recently extinct volcano for observation and study from local to global levels.
- Capulin Volcano is part of the geologically and morphologically diverse Raton-Clayton Volcanic Field, the easternmost Cenozoic volcanic field in North America.
- The breathtaking panoramic view from the crater rim provides opportunities for education and scientific investigation of natural and cultural landscapes, including how the features were formed and how the volcanic landforms helped shape the human history of northeastern New Mexico.

Elevation

The average elevation at the park is approximately 7,500 feet. Of the 15 national parks in New Mexico, only Bandelier National Monument and Valles Caldera National Preserve top Capulin’s elevation of 8,182 feet. Neither place provides the accessibility of CAVO’s Crater Rim Trail and Crater Vent Trail which allow over 55,000 annual visitors the opportunity to experience the volcano by hiking around the perimeter or down into the center of the crater. From atop the volcano visitors can view other peaks and volcanoes in the field for a distance of up to 146 miles on a clear day with the naked eye. A road leading to the top of the volcano was constructed in 1925 which spirals around the cinder cone ending at a parking lot located at the summit. The Volcano Road provides easy access to the top of the mountain where visitors are afforded fantastic sweeping views of the surrounding, minimally developed landscape.

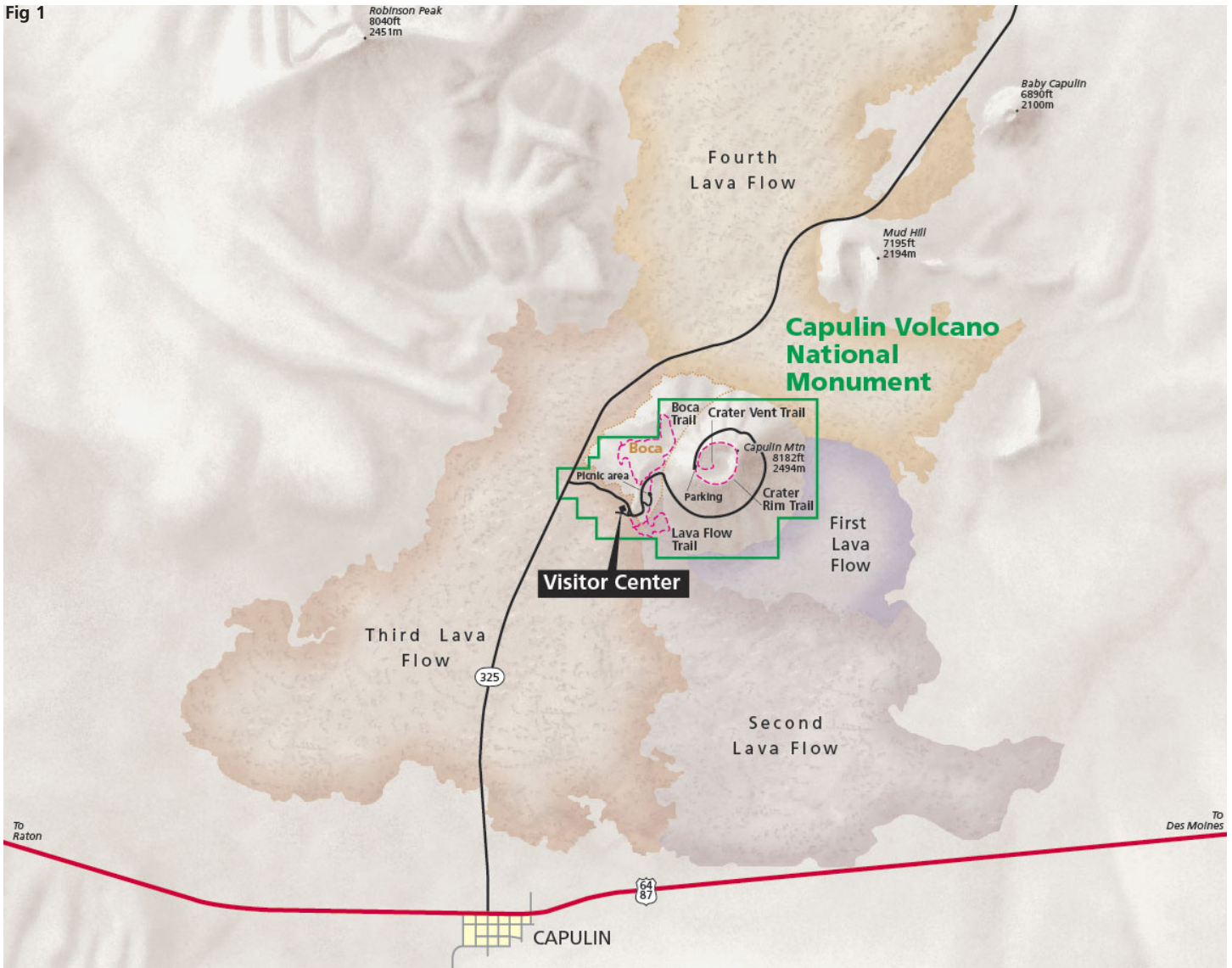
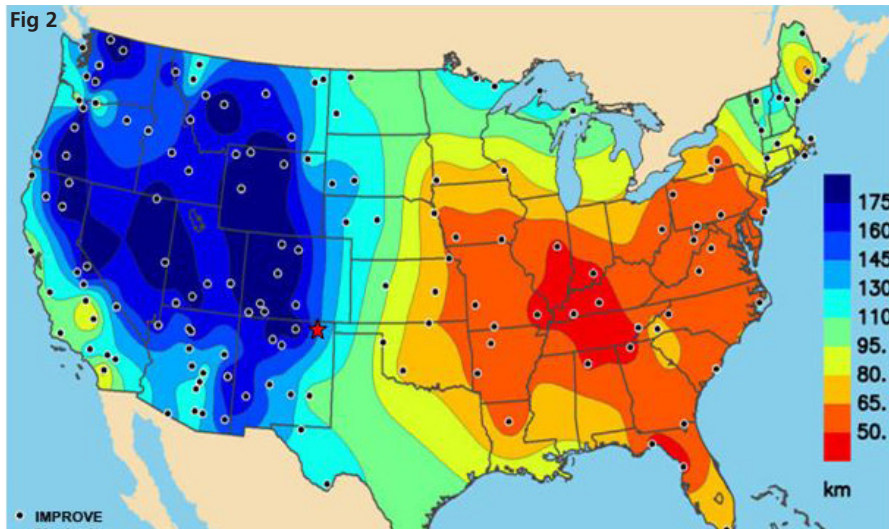

Fig. 1: Map showing the location of Capulin Volcano

Fig. 2: Indicated by the red star, Capulin Volcano's average visibility is approximately 80 to 100 miles.



Visibility

Many of the most wonderful natural places in the U.S. are protected in some form or fashion. The enjoyment of these protected areas and their resources such as the night sky relies heavily on the ability to see through clear atmospheric conditions. In most cases, air pollution can be a major depreddating factor. Limited pollutants, such as nitrates, dust, and sulfates floating in the atmosphere surrounding CAVO allow excellent human visibility.

The map to the left shows visibility conditions present across the country. The data was collected by the Interagency Monitoring of Protected Visual Environments (IMPROVE). IMPROVE began data collection with the EPA and National Park Service in 1979, and has expanded to the U.S. Forest Service, U.S. Fish and Wildlife Service, Bureau of Land Management, and NOAA.

Weather and Climate

Northeastern New Mexico averages 10 – 20 inches of rain annually. The southwest region has experienced abnormally high precipitation amounts this year. In fact, according to the National Oceanic and Atmospheric Administration (NOAA), this region has experienced the wettest year in 121 years. As you can see, for the year of 2014 CAVO experienced around 15 inches. The month of May 2015 brought in at least six inches, which are nearly half the previous annual totals in one month alone.

The elevation, slope and aspect variations, and local atmospheric zone in which CAVO exists often creates a small microclimate. A microclimate is any region or section of the earth in which the climate differs from the surrounding lands. Microclimate conditions that often experienced at the park are higher precipitation levels (rain, snow, fog), more violent winds, and temperature fluctuations.

Fig. 3: Maps courtesy of The National Oceanic and Atmospheric Administration

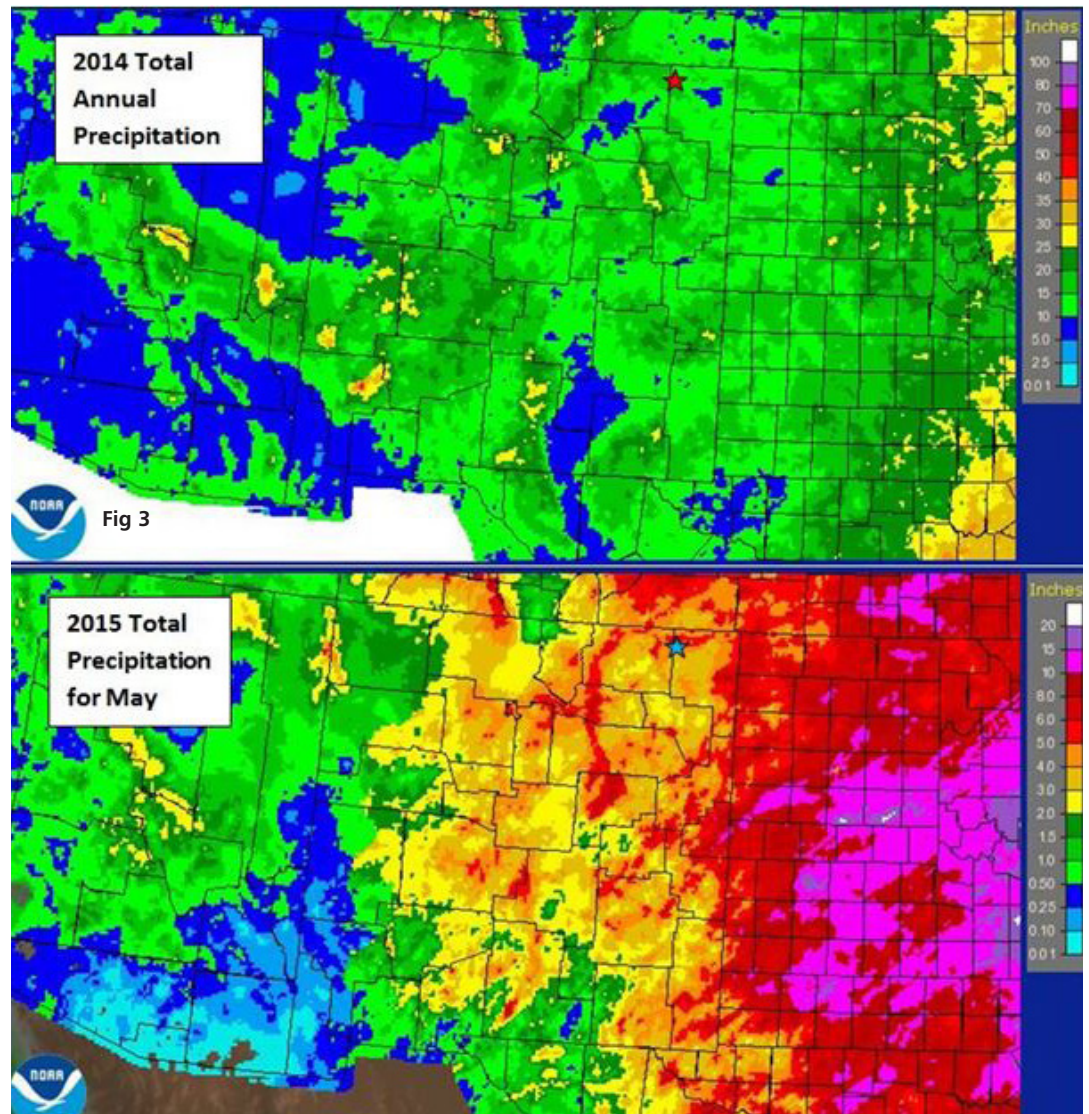

Population Density

The surrounding 55-mile area comprises a total population of approximately 15,811 individuals. Of that population only 258 live within a 25 square mile radius of the park. Generally speaking, fewer humans equates to less light pollution. Seclusion from human development is one of the many reasons we believe our park has such a high quality night sky.

Fig 4: Towns within 25 miles of CAVO

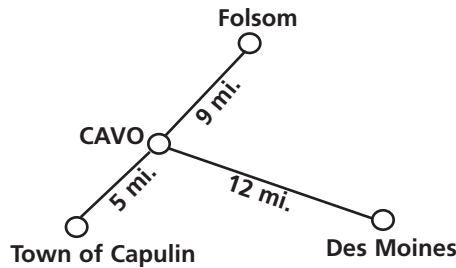

Numerous efforts have been made over several years to reach out to the surrounding community about night sky opportunities and management decisions. Press releases and radio announcements continue to be made inviting guests to CAVO star parties and informing them of other local opportunities such as those held at Clayton Lake State Park.

Social media content allows park staff to reach out to local community members and inform them of real time night sky related management decisions to gain community perspective and input. Four annual summer markets are hosted on the monument that attract hundreds of local community members. Each summer market a night sky tent with solar telescopes is set up for public viewing and night sky related questions.

Light Barriers

Another factor to consider is the natural fortress that surrounds the park. As mentioned earlier, our monument rests in the Raton-Clayton Volcanic field, an 8,000 square mile volcanic territory with approximately 120 volcanoes and numerous mesas and buttes. Many of these landforms rise as high as 2,000 feet above the surrounding plains and stretch from 1 to 14 miles. These towering landmasses act as great low level light source interceptors for things such as vehicle headlights. Capulin is directly surrounded by approximately of 17 miles of volcanoes, mesas and buttes.

Surrounding Communities

Population

Fig 5

Town	State	Population
Capulin (5 mi.)	NM	66
Folsom (9 mi.)	NM	57
Des Moines (12 mi.)	NM	135
Branson (26 mi.)	CO	69
Grenville (33 mi.)	CO	36
Raton (35 mi.)	NM	6326
Clayton (55 mi.)	NM	2874
Trinidad (55 mi.)	CO	8248

Fig. 5: Local population within 55 miles of the park.

The park has completed outreach efforts to all of the surrounding towns. Some of the efforts include the following:

- Offered night sky programs
- Held science programs at the park and at local schools some of which were funded through grants organized by the park
- Hired local residents to hold internships and seasonal jobs for the park
- Organized a Youth Conservation Corps group based out of Raton, Des Moines, and Folsom to complete park beautification projects
- Completed service projects, and interpretive programming with local and state parks and museums located in Trinidad, Clayton, and Raton
- Developed park exhibits based on community created films, designs, and inputs.



Fig. 6: U.S. Light pollution

This U.S. map image provided by NASA and The National Oceanic and Atmospheric Administration shows the glow of light pollution across the continental United States in great detail. As you can see, our park (indicated by the red star) is secluded away from light pollution in some of the darkest territories of the U.S.

Light pollution is directly related to human developments. The source can be from either interior or exterior building lighting, street lights, billboards, special events, and many more.

The major problem with these lights is that many of them are too bright, inefficient, spreading over unnecessary areas, or not necessary in the first place. Humans don't need light in the sky to navigate around at night, it is only necessary on the ground.

The unnecessary spread of light into the atmosphere has negative impacts on the environment. The most obvious impact is the loss of the night sky. Lights overpower the glow of the moon, sun, and stars that were once easily visible. Light pollution also wastes energy and money and disrupts the daily light and dark cycle that humans, plants, and animals depend on.

Capulin Volcano is committed to eliminating existing light pollution in the surrounding area and preventing it from occurring in the future to help keep the western U.S. a haven of dark skies.

Dark Sky Park Status

Capulin Volcano National Monument is requesting designation from IDA as an International Dark Sky Park. Multiple efforts have been set forth in order to meet the IDA requirements expected by all applicants.

Dark Sky Commitment

The National Park service (NPS) has demonstrated an on-going commitment towards both interpreting and measuring dark sky resources. CAVO seeks to not only administer these overlying NPS dark sky principles, but to consider the night sky as a fundamental resource or value that is to be preserved. In fact, CAVO has implemented night sky considerations into the park Foundation Document.

The Foundation Document specifically calls for action regarding the night sky in 3 sections. The first section states that the monument and surrounding communities are to work

collaboratively towards the development of night sky interpretive themes and to enhance dark night sky conditions by retrofitting their exterior light fixtures to reduce light pollution.

The second section states that CAVO is to continue to pursue and enhance partnerships with The International Dark Sky Association, regional colleges, local astronomy clubs, and others. Lastly the foundation document implies that there should be stakeholders of the night sky as a fundamental resource or value including 10 educational, tribal, political, or local social groups within a 100 mile radius.

Fig 7: A comparison of the required conditions to meet GOLD dark sky park criteria to the conditions present at CAVO.

Tier Designation Breakdown Capulin Volcano National Monument		
Designation	Gold	Explanation
Philosophy	Nighttime environments that have negligible to minor impacts from light pollution and other artificial light disturbance, yet still display outstanding quality night skies and have superior lightscapes.	The 15 square mile radius surrounding the park is home to only approximately 258 residents. Light pollution is very scarce, and night sky quality enjoys the benefits.
Artificial Light and Skyglow	Typical observer is not distracted by glary light sources. Light domes are only dim and restricted to sky close to horizon.	Skyglow from 7,877 feet elevation is very faint and restricted to approximately 15 degrees of the horizon towards the N. NW.
Observable Sky Phenomena	The full array of visible sky phenomena can be viewed.	Clear nights produce visibility of numerous astronomical phenomena. The Milky Way and Orion Nebula can be seen by the naked eye.
Nocturnal Environment	Area is devoid of obvious lights that can cause wildlife disorientation. Artificial light levels are thought to be below the threshold for plant and animal impact. Ecological processes related to nocturnality are unaltered. No lighting atop towers or buildings within park boundary.	Any exterior lights that come on at night are either on a curfew or fully shielded. The park has no lighting atop towers or buildings within the park.
Visual Limiting Magnitude	Equal or greater than 6.8 under clear skies and good seeing conditions.	The average visual limiting magnitude observed at Capulin Volcano is 7.06. (see night sky quality report page XX)
Bortle Sky Class	1 - 3	2
Unihedron Sky Quality Meter	> 21.75	21.51 - Although not greater than 21.75, our sky quality meter and indexes rank amongst the best in the U.S.

Existing Conditions

All exterior lighting on park property has been reconstructed to provide the minimal necessary lighting for visibility and navigation purposes. A lighting management plan is underway to document and maintain the changes implemented to achieve 100% compliance with outdoor lighting regulations and future plans to improve existing compliant lighting fixtures. The park believes that these night sky friendly efforts and adjustments will cultivate the enjoyment, education, and inspiration of all that encompasses an amazing night sky experience for this and future generations. With this in mind, interpretive staff is set to complete outreach opportunities and training for night sky collaboration and education with other night sky professionals.

Professional Assessments & Measurements

Capulin Volcano National Monument's night sky offers spectacular views of starry nights, providing visitors a tremendous recreational opportunity of star-gazing. The night sky has been identified as one of the monument's fundamental resources and values and is among the top 20 darkest night skies measured in 90+ national parks with extremely minimal light pollution. The monument's night sky is situated along the edge of a "dark hole"-an area largely devoid of light pollution-, which extends from southwest of La Junta, CO to northeast of Las Vegas, NM.

The park exemplifies the specified criteria sought for appointment as a Dark Sky Park. As shown in the tier designation breakdown, Capulin Volcano is home to some of the best quality dark sky conditions in the United States.

Together, the NPS and IDA developed the "Night Sky Quality Monitoring Report"—a system for measuring sky brightness to accurately understand the severity of light pollution on a given area. Observed and estimated artificial sky brightness mosaics and photometric indicators were recorded by the NPS team in 2008 and most recently in 2009 for CAVO.

In assessing the quality of Capulin Volcano's night sky, three measures were considered—all relating to the darkness of the sky and the lack of artificial light. Two of the measurements, Bortle Dark-Sky and limiting magnitude

scales, are commonly used by amateur astronomers, providing a qualitative assessment of night sky darkness. These along with the measurements of sky brightness were collected by NPS Night Skies scientists using charged coupled device cameras that capture night sky images from which sky brightness at the darkest and brightest areas and integrated sky brightness (both whole sky and above 20 degrees) are gathered. At present, the monument has one of the darkest night skies throughout the park service and scores a 2 on the 1-9 Bortle dark sky class and a limiting magnitude between the range of 7.1 and 7.2. This value corresponds to the low end of Bortle Class 2, though there are many factors that confound an exact translation of one system to another.

Additionally, the sky brightness values at the monument are consistent with a night sky in great condition, though the data also show the notable impact of light pollution along the horizon.

Category	Details
Park:	Capulin Volcano NM
Site Name:	South edge summit
Longitude:	-103.97
Latitude:	36.78
Elevation (m):	2471
Date (LMT):	17-NOV-2009
Time (LMT Hours):	22.72
Camera:	IMG 3
Lens:	Nikon 1.8
Observers:	T Jiles; T Teters
Air temp. (°C):	2.8
R.H. (%):	28.0
Wind Speed (mph):	2
Extinction Coeff. (mag/airmass):	.14
NELM:	7.2
Bortle Class:	2
SyntheticSQM:	21.51
SQM All-sky:	95.7
SQM to Z.A. 70°:	99.5
Number of stars visible:	4220
Narrative: Very clear night with excellent transparency and seeing. Orion nebula visible naked eye. Airglow visible on horiz. to NNW. SQM of 21.92	

Indicator	Observed	Estimated Artificial		Light Pollution Ratio (Artificial/Natural)
		mag/arcsec2	mag/arcsec2	
Sky Luminance Measures				
Zentih	ucd/ m2	254	ucd/ m2	< 0.10
	mag/arcsec2	21.58	mag/arcsec2	
Mean all-sky	ucd/ m2	323	ucd/ m2	0.10
Brightest	mag/arcsec2	19.58	mag/arcsec2	7.92
Darkest	mag/arcsec2	21.70	mag/arcsec2	< 0.10
Median	mag/arcsec2	21.37	mag/arcsec2	0.04
Illuminance Measures				
Horizontal	mags	-6.38	mags	0.03
	milli-lux	0.90	milli-lux	
Max Vertical	mags	-5.89	mags	0.18
	milli-lux	0.58	milli-lux	0.07

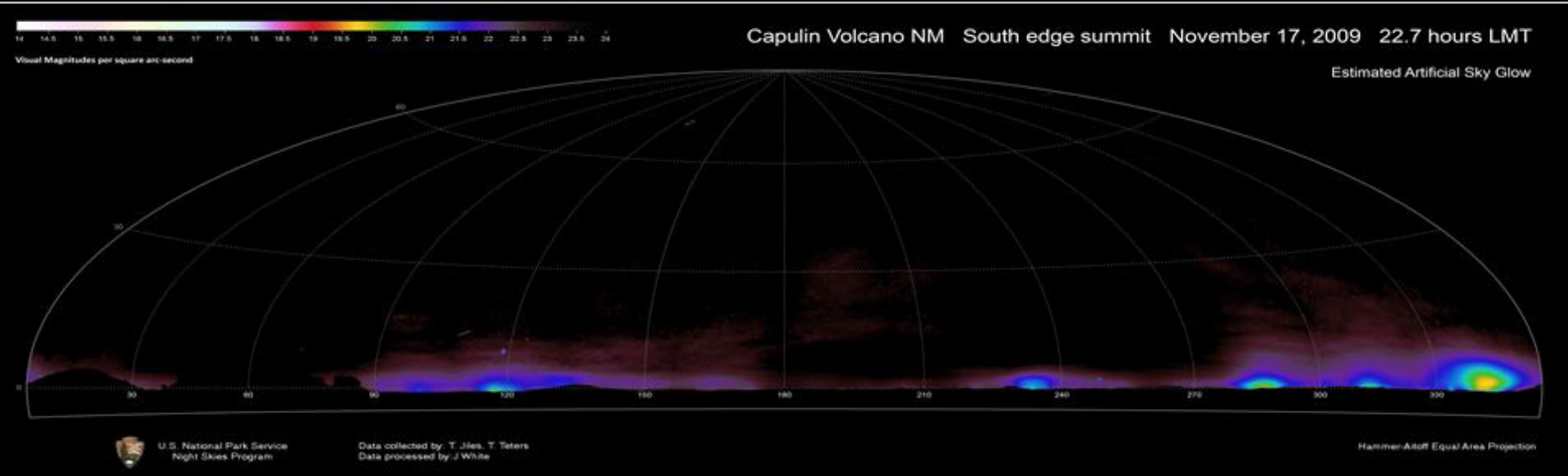
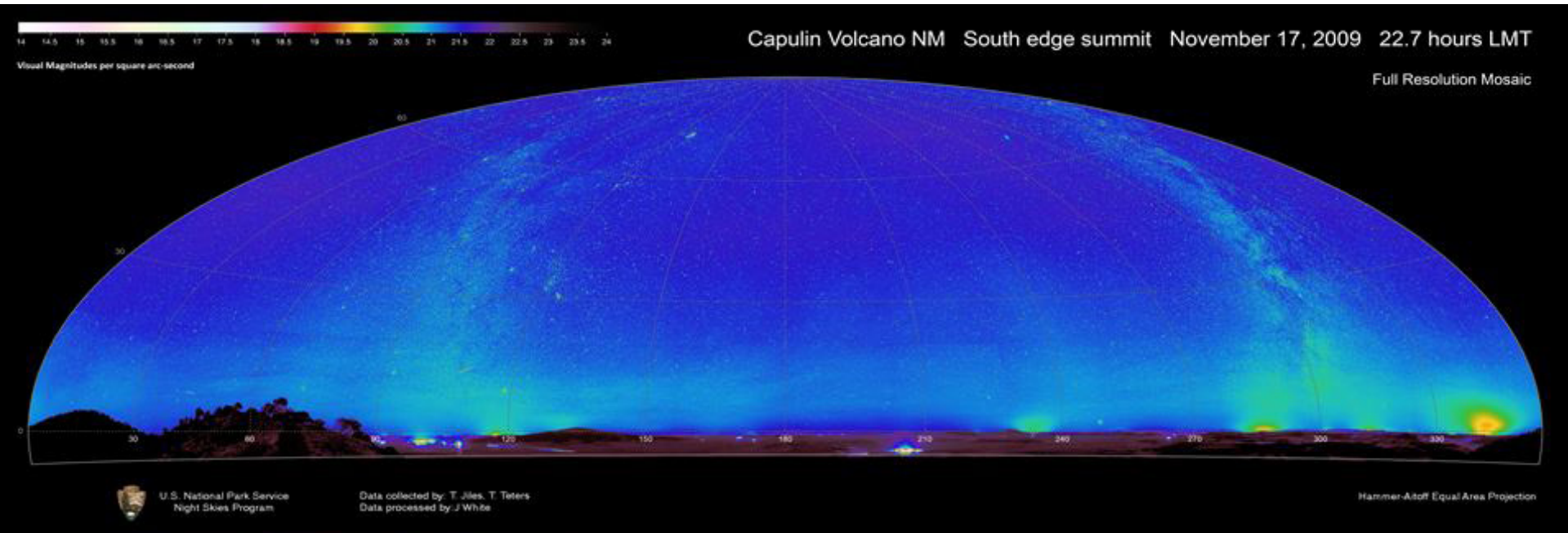

Category	Details
Park:	Capulin Volcano NM
Site Name:	South edge summit
Longitude:	-103.97
Latitude:	36.78
Elevation (m):	2471
Date (LMT):	17-NOV-2009
Time (LMT Hours):	22.72
Camera:	IMG 3
Lens:	Nikon 1.8
Observers:	T Jiles; T Teters
Air temp. (°C):	2.8
R.H. (%):	28.0
Wind Speed (mph):	2
Extinction Coeff. (mag/airmass):	.14
NELM:	7.2
Bortle Class:	2
SyntheticSQM:	21.52
SQI All-sky:	94.9
SQI to Z.A. 70°:	98.8
Number of stars visible:	4120
Narrative: Very clear night with excellent transparency and seeing. Orion nebula visible naked eye. Airglow visible on horiz. to NNW. SQM of 21.92	

Indicator	Observed	Estimated Artificial		Light Pollution Ratio (Artificial/Natural)
		mag/arcsec2	mag/arcsec2	
Sky Luminance Measures				
Zenith	ucd/ m2	247	ucd/ m2	< 0.10
	mag/arcsec2	> 24.5	< 17	
Mean all-sky	ucd/ m2	321	ucd/ m2	0.11
Brightest	mag/arcsec2	19.58	mag/arcsec2	7.98
Darkest	mag/arcsec2	21.72	mag/arcsec2	< 0.10
Median	mag/arcsec2	21.38	mag/arcsec2	0.05
Illuminance Measures				
Horizontal	mags	-6.37	mags	0.04
	milli-lux	0.90	milli-lux	
Max Vertical	mags	-5.88	mags	0.20
	milli-lux	0.57	milli-lux	0.08

Capulin Volcano NM South edge summit November 17, 2009 22.7 hours LMT
Estimated Artificial Sky Glow

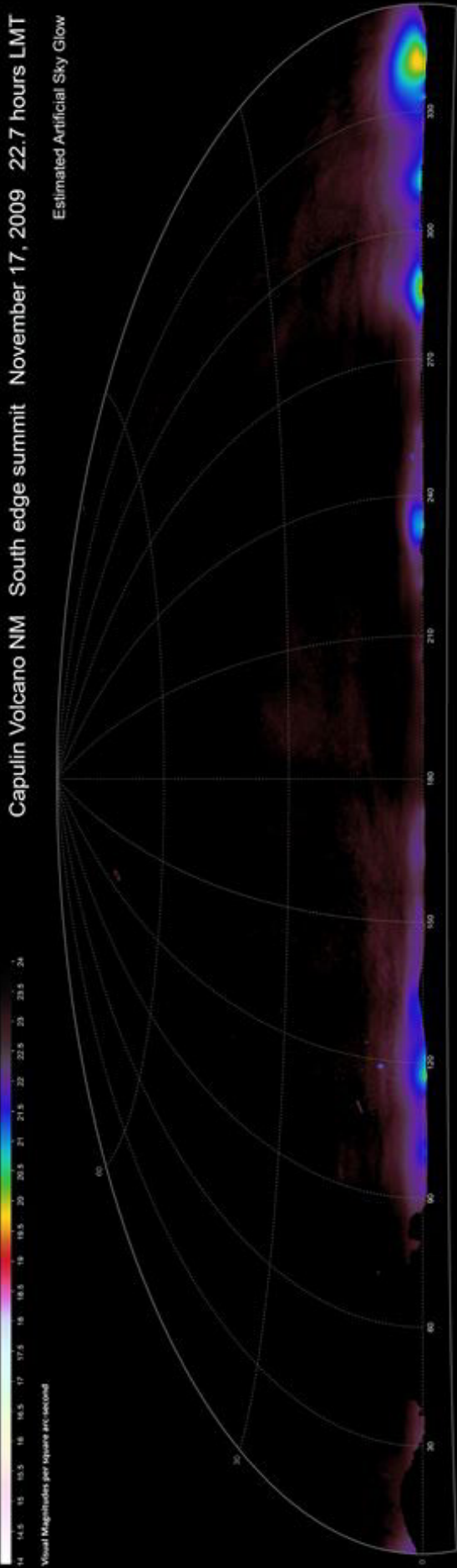

Capulin Volcano NM South edge summit November 17, 2009 22.7 hours LMT
Full Resolution Mosaic

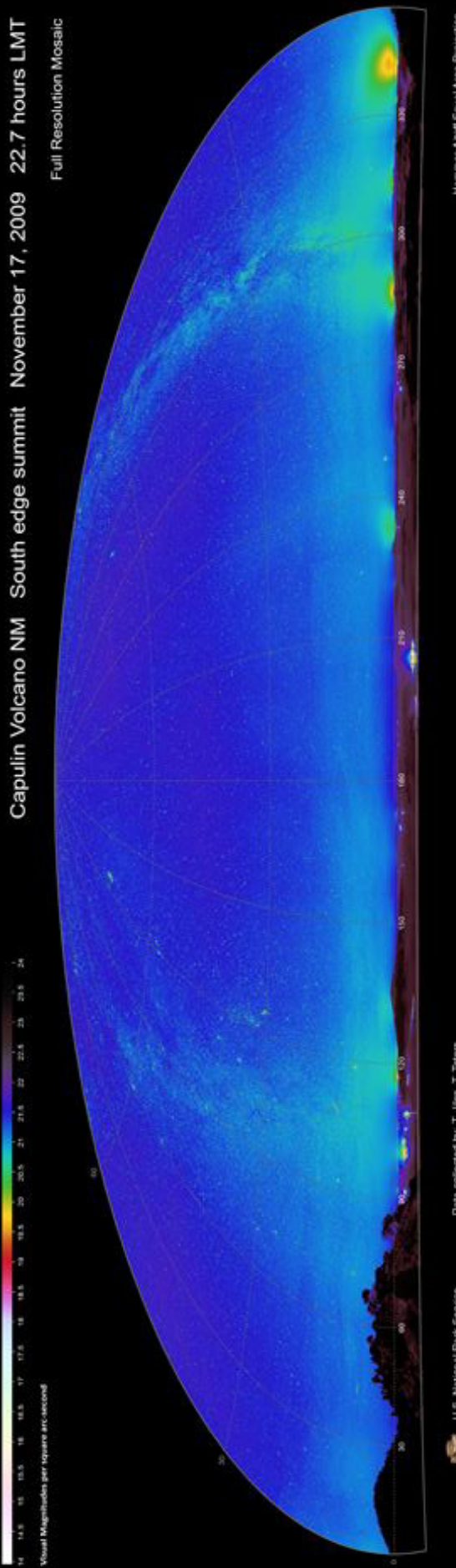

Comparison—Capulin vs. Clayton

Capulin Volcano rests in Union County with Clayton Lake State Park (CLSP) just 70 miles to the southeast. Clayton Lake has been a Gold Tier status IDA park since 2006. CLSP is also home to the Star Point Observatory, a publicly available solar powered observatory in service since 2006. Capulin Volcano has a high quality night sky just as our impressive neighbor CLSP. Below is a comparison of the NPS data recordings between the two parks. The data comparison should be helpful as the locations are so close in proximity and similar in nature.

Ongoing Monitoring and Data Collection

In order to protect the validity of these efforts, however, we will continue to take measurements. The park purchased a basic Unihedron Sky Quality Meter to collect annual data such as artificial sky brightness in 12 different locations. Staff will also continue to take photos at a few of the locations to document photo evidence of night sky conditions.

The park has also purchased a continuous data logging Unihedron Sky Quality Meter and a telescope camera eyepiece to assist in night sky efforts. The park plans on reaching out to park volunteers, seasonal employees and local community members to assist in the annual data collection projects.

Fig. 8: Side by side comparison of Night Sky Quality Monitoring Reports from Capulin Volcano and Clayton Lake State Park

Category	Details	Details
Park:	Capulin Volcano NM	Clayton Lake SP
Site Name:	South edge summit	Overlook Beyond Star Point
Longitude:	-103.97	-103.30
Latitude:	36.78	36.57
Elevation (m):	2471	1587
Date (LMT):	17-NOV-2009	18-NOV-2006
Time (LMT Hours):	10:45 p.m.	1:53 a.m.
Camera:	IMG 3	
Lens:	Nikon 1.8	
Observers:	T Jiles; T Teters	K. Magargal
Air temp. (°C):	2.8	5
R.H. (%):	28.0	43
Wind Speed (mph):	2	0
Extinction Coeff. (mag/airmass):	.14	.14
NELM:	7.2	7.1
Bortle Class:	2	2-3
Zenith (mag/sq arc-sec²)	21.58	21.56

Capulin Volcano National Monument General Overview



Fig 9

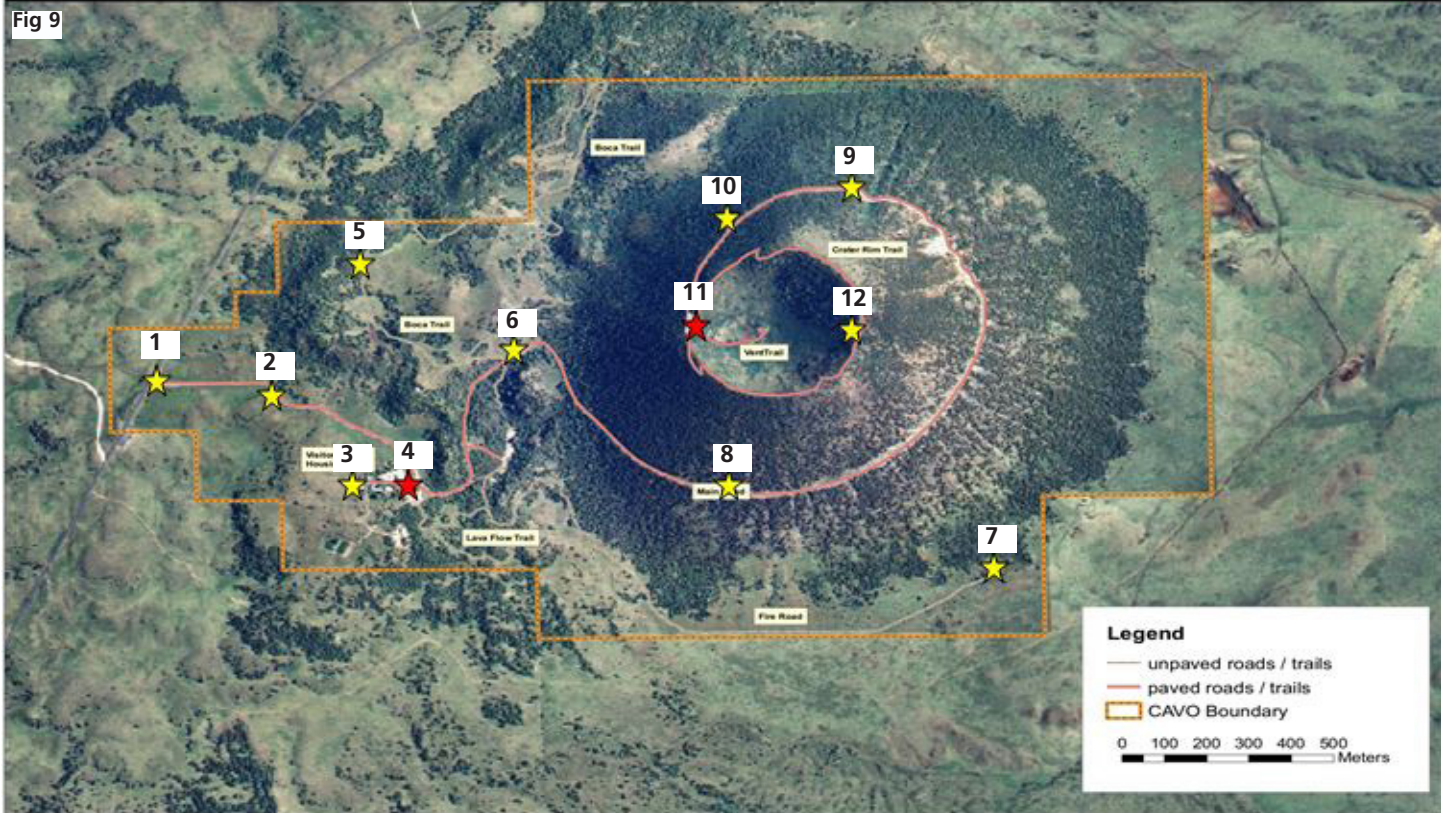

Fig 9: Sky Quality Meter observation points for data collection at CAVO

Fig 10: Sky Quality Meter data collection results on April 7th, 2016.

The most recent measurements taken at CAVO were on April 7th, 2016 with the use of a Unihedron Sky Quality Meter (SQM). In order to provide the most accurate estimates we collected the data at 12 different observation points and the results are indicated in Figure 10.

In addition to the basic Unihedron Sky Quality Meter, we also purchased a continuous data logging SQM for more accurate long term records of the night sky conditions. The park is committed to continue to monitor the conditions of the night sky in future years.

As you can see, the SQM measurements we obtained support our claim that we have little reason to suggest that the night sky data reports from 2009 would differ if completed yet again in 2016. In fact, the new measurements indicate an even lower concentration of light pollution.

Fig 10:

Observation Points	Sky Quality Meter (SQM)
1	21.94
2	21.95
3	21.95
4	21.93
5	21.89
6	21.88
7	21.95
8	21.90
9	21.89
10	21.94
11	22.01
12	21.98

Lighting Inventory and Management

Capulin Volcano National Monument is requesting designation from IDA as an International Dark Sky Park. Multiple efforts have been set forth in order to meet the IDA requirements expected by all IDA park applicants.

The research conducted by the NPS Night Skies Team shows that CAVO hosts a high quality dark sky with extremely minimal light pollution. Our park exemplifies the specified criteria sought for appointment as a dark sky park. Per the lighting inventory breakdown, all lights on park property are compliant with The Guidelines for Outdoor Lighting (GOL). The dark sky at Capulin Volcano is breathtaking and we hope you will contemplate CAVO as a Gold Tier status designation.

All exterior lighting on park property has been reconstructed to provide the minimal necessary lighting for visibility and navigation purposes. The lighting management plan will document and maintain the changes implemented to achieve 100% compliance with outdoor lighting regulations and future

plans to improve existing compliant lighting fixtures. The park believes that these night sky friendly efforts and adjustments will cultivate the enjoyment, education, and inspiration of all that encompasses an amazing night sky experience for this and future generations. With this in mind, interpretive staff is set to complete outreach opportunities and training for night sky collaboration and education with other night sky professionals.

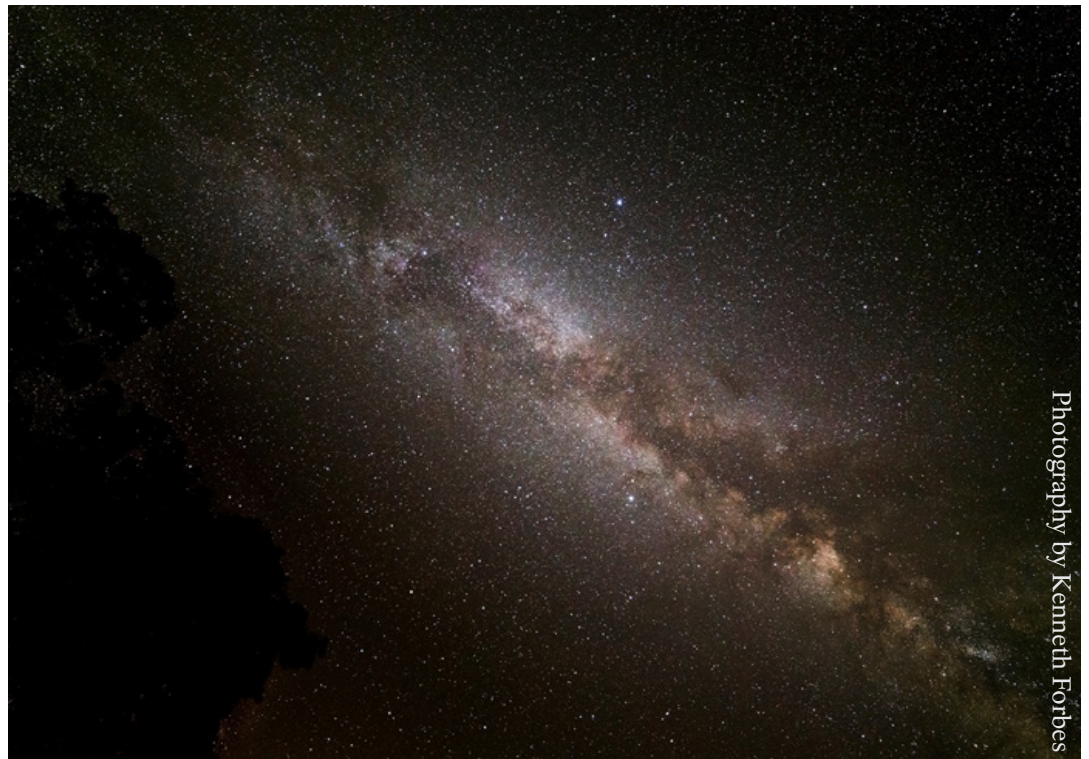

Photography by Kenneth Forbes

Summary

The Guidelines for Outdoor Lighting (GOL) for Dark-sky Preserves and IDA Dark Sky Places indicate some of the best practices and rules of thumb for facilitating a quality nighttime environment. All guidelines should be followed as policy for lighting at CAVO. A few of the basic guidelines include the following:

- Lighting fixtures above 500 lumens need to be either fully shielded or set to a curfew or timer.
- Nighttime lighting units should be contemplated for validity unless utilized for increasing visibility purposes.
- The correlated color temperature of the lamps are not to exceed 4000K.

- Facilities only require illumination when open or available to people.
- To minimize light pollution, lighted pathways should be illuminated only when pedestrians can benefit from them.
- The duration of lighted periods should be kept to a minimum with devices such as motion sensors and time delays.

These six (GOL) guidelines amongst others were put into action at CAVO, and the changes have been documented in summary throughout the lighting and inventory management section.

Fig 11: Summary of all park lights that emit light into the night sky.

Exterior and Interior Park Lights					
	Total Lights	Mitigated Lights	Compliant	Incompliant	Compliance%
Visitor Center	7	5	7	0	100
Employee Housing	10	10	10	0	100
Total	17	15	17	0	100

Capulin Volcano is a small park at only 793 acres. As you will notice in the following reports, we also require only a small amount of lighting as well. The specific areas of concern at CAVO include pathways, parking lots, and developed properties within park facilities. The modifications made to lighting fixtures in the park brings the compliance rate to 100% under GOL lighting regulations.

Before we started the new night sky program, there was only one light that was out of compliance. Staff removed the light and it will be replaced with a fully shielded fixture as soon as funding requests are met. The miniscule number of lights emitting into the atmosphere from the park is just one more reason that we have such an amazing star view shed at the monument.

Lighting Inventory and Management—The Visitor Center

ID#	Use	Specifications	Shield	Curfew/ Timer	Notes All Lights < 4000K	Compliant with GOL
1	Administrative Office Entry	Halogen Flood <ul style="list-style-type: none"> • 275 watt • 5,000 lumens 	Partial	Timer	Working to fully shield	Yes
2	Fire Cache	Dual LED Flood <ul style="list-style-type: none"> • 10.5 watt • X2 480 lumens 	Partial	Timer	Working to fully shield	Yes
3	Employee Main Entrance	Halogen Flood <ul style="list-style-type: none"> • 150 watt • 2,400 lumens 	Partial	Timer	Working to fully shield	Yes
4	Management Back Office	High Pressure Sodium Fixture <ul style="list-style-type: none"> • 150 watt • 3,600 lumens 	No	On/Off Switch	Working to fully shield	Yes
5	Park Store Security	Incandescent Tube Fixture <ul style="list-style-type: none"> • 28 watt • X2 2750 lumens 	Partial	No	Removed-replace with fully shielded	No
6	Visitor Main Entrance 1	High Pressure Sodium Fixture <ul style="list-style-type: none"> • 150 watt • 2,400 lumens 	No	Timer	Working to fully shield	Yes
7	Visitor Main Entrance 2	High Pressure Sodium Fixture <ul style="list-style-type: none"> • 150 watt • 2,400 lumens 	No	Timer	Removed-replace with fully shielded	Yes

Fig 13: Visitor Center individual lighting fixture specifics

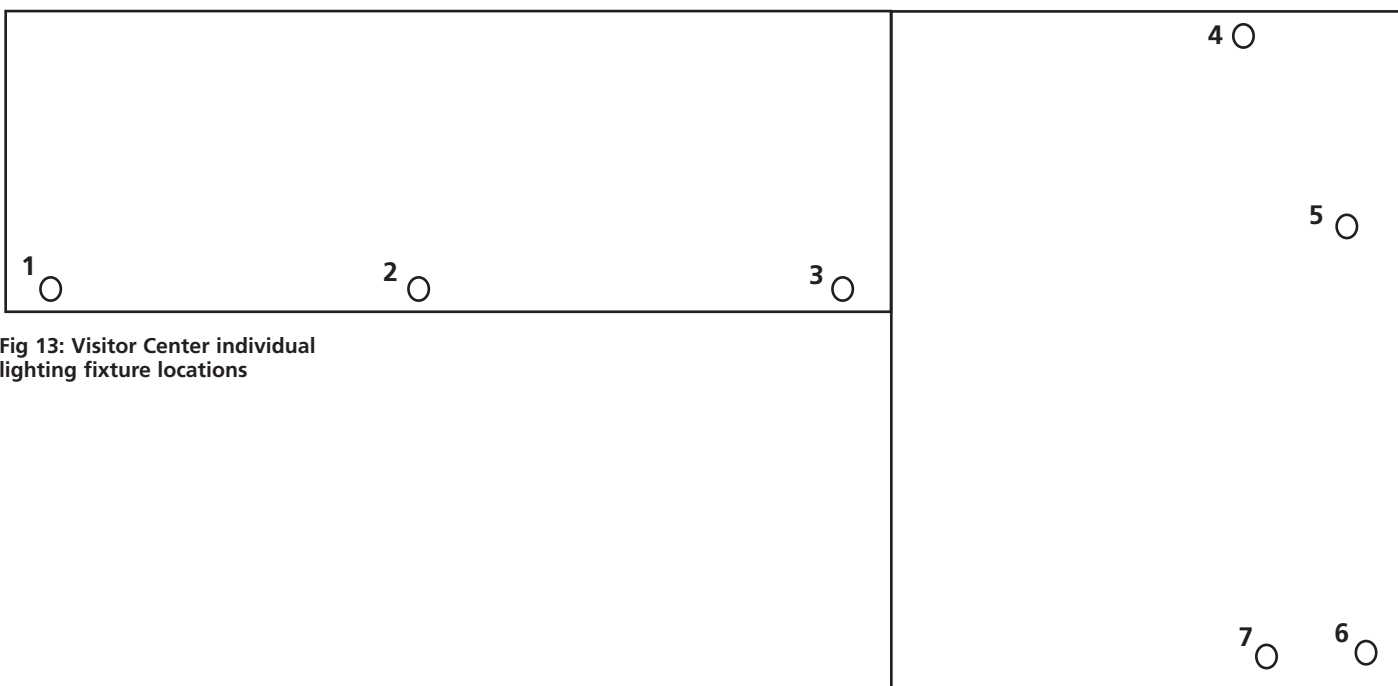

Fig 13: Visitor Center individual lighting fixture locations

Fig 14: Visitor Center individual lighting fixture mitigations







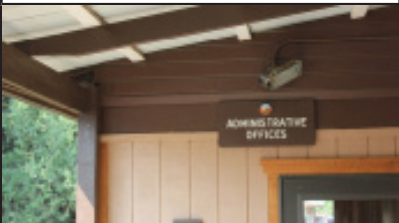

ID #	Existing Fixture or Bulb	Post Mitigation (if necessary)	Notes
1			<ul style="list-style-type: none"> - Timer - Turned down sensitivity and directed downwards towards building. Working to fully shield.
2	<p>Cassins Kingbird nest we worked around!</p> 		 <p>Replaced 100 watt 850 lumen incandescent bulbs with 10.5 watt 480 lumen LED bulbs</p>
3			<ul style="list-style-type: none"> - Timer - Turned down sensitivity and directed downwards towards necessary pathway. Working to fully shield.
4			<ul style="list-style-type: none"> - On / Off switch - Working to fully shield
5			<ul style="list-style-type: none"> - Inside Visitor Center - Security light had been shining outside through the windows - To be replaced with fully shielded fixture
6			<ul style="list-style-type: none"> - Timer - Working to fully shield
7		<p>Not necessary for visibility. Light #6 is roughly 10 feet apart from light #7.</p>	<p>Eliminated</p>

Fig 15

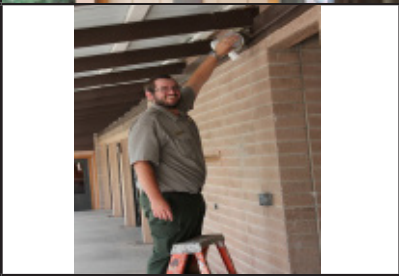
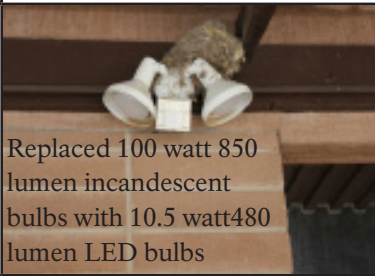
Lighting Inventory and Management—Employee Housing

ID#	Use	Specifications	Shield	Curfew/ Timer	Notes All Lights < 4000K	Compliant with GOL
8	Garage/drive-way entry	Halogen Flood • 150 watt • 2,400 lumens	No	Timer	Working to fully shield	Yes
9	Front Porch	LED Bulb • 7.5 watt • 500 lumens	No	On / Off switch	Recent mitigation (LED)	Yes
10	Back Porch	LED Bulb • 7.5 watt • 500 lumens	No	On / Off switch	Recent mitigation (LED)	Yes
11	Garage Entry	LED Bulb • 7.5 watt • 500 lumens	No	On / Off switch	Working to fully shield	Yes
12	Garage / Drive-way Entry	Halogen Flood • 150 watt • 2,400 lumens	No	Timer	Working to fully shield	Yes
13	Front Porch	LED Bulb • 7.5 watt • 500 lumens	No	On / Off switch	Recent mitigation (LED)	Yes
14	Back Porch	LED Bulb • 7.5 watt • 500 lumens	No	On / Off switch	Recent mitigation (LED)	Yes
15	Garage / Drive-way Entry	Halogen Flood • 150 watt • 2,400 lumens	No	Timer	Working to fully shield	Yes
16	Front Porch	LED Bulb • 7.5 watt • 500 lumens	No	On / Off switch	Recent mitigation (LED)	Yes
17	Back Porch	LED Bulb • 7.5 watt • 500 lumens	No	On / Off switch	Recent mitigation (LED)	Yes

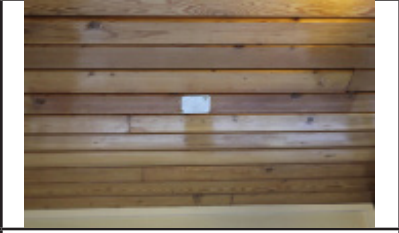
Fig 15: Employee Housing individual lighting fixture specifics

Fig 16: Employee Housing individual lighting fixture locations

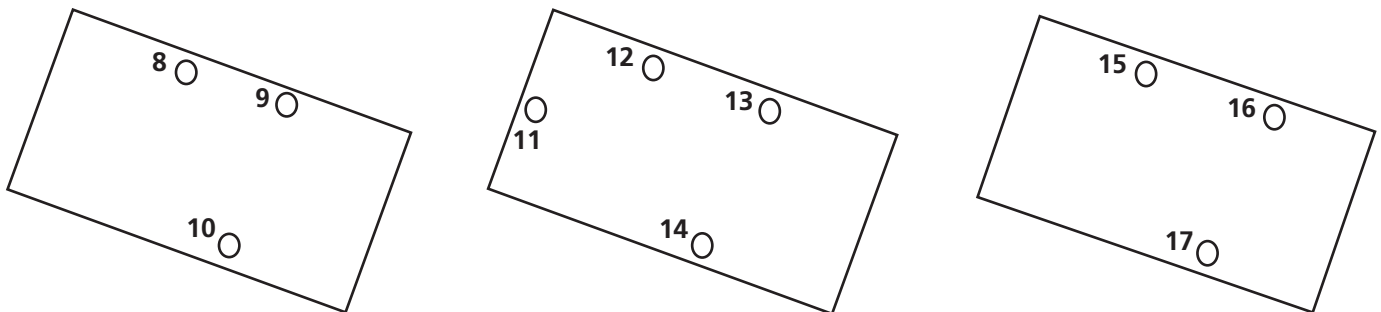





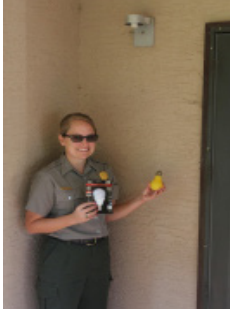















Fig 17: Employee Housing individual lighting fixture mitigations

ID #	Existing Fixture or Bulb	Post Mitigation (if necessary)	Notes
8			<p>Turned down sensitivity and aimed downwards towards necessary pathway</p>
9			<p>Replaced 13 watt 850 lumen CFL bulb with 7.5 watt 500 lumen LED bulb</p>
10			<p>Replaced 75 watt 650 lumen incandescent bulb with 7.5 watt 500 lumen LED bulb</p>
11			<p>Replaced 75 watt 650 lumen incandescent bulb with 7.5 watt 500 lumen LED bulb</p>
12			<p>Turned down sensitivity and aimed downwards towards necessary pathway</p>
13			<p>Replaced 75 watt 650 lumen incandescent bulb with 7.5 watt 500 lumen LED bulb</p>

ID #	Existing Fixture or Bulb	Post Mitigation (if necessary)	Notes
14			Replaced 75 watt 650 lumen incandescent bulb with 7.5 watt 500 lumen LED bulb
15			Turned down sensitivity and aimed downwards towards necessary pathway
16			Replaced 75 watt 650 lumen incandescent bulb with 7.5 watt 500 lumen LED bulb
17			Replaced 75 watt 650 lumen incandescent bulb with 7.5 watt 500 lumen LED bulb



Interpretation and Education

Fig 18: Night sky program agenda examples

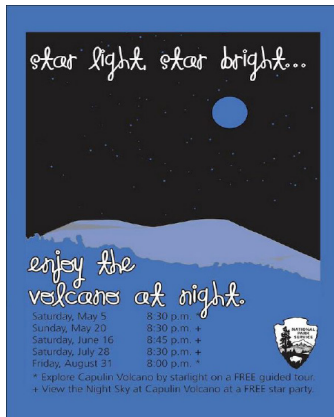

Capulin Volcano National Monument is supported by a strong interpretive team. During the year, the park hosts approximately seven interpretive employees including permanent and seasonal positions. CAVO employees are extremely committed to a teamwork environment day in and day out. A high level of interpretive achievement has been on display for years at the park and in the surrounding community.

Current Efforts

We are currently working on training staff to bring night sky efforts to a higher level for the interpretive program, therefore meeting our foundation document goals. Staff receive the trainings to keep their night sky programs informative and engaging.

Amarillo College Professor Art Schneider is teaching the night sky at CAVO from an astronomer's standpoint. Art has volunteered at the park for several years as a Night Sky Astronomer. He has held numerous astronomy events at the park including daytime viewing events over the past two years. Hundreds of visitors were able to experience live views of the sun and the associated sunspots and prominences through two stationed solar telescopes.







Beyond park hosted star programs, visitors are allowed 24/7 access to the park for unrestricted night sky viewing opportunities.

As soon as the staff are trained, **CAVO will host anywhere from 5 – 7 night sky programs annually.** Our interpretive efforts will also extend outwards towards collaboration with other parks such as Clayton Lake State Park, a Gold Tier status IDA Park located just 70 miles southeast of the monument. CAVO owns a computerized 8-inch Orion telescope and a 3 inch Meade telescope for outreach programs.



Fig 19: CAVO data from the Unihedron Sky Quality Meter Database

SQM Observations for *Capulin Volcano National Monument*

	ID	UT datetime	Type	Brightness	Zenith	Conditions	Moon alt.	Moon illum.	Location
 	3749	2016-04-07 12:05:03	SQM	21.94	Up	clear	-9°	0%	Park Entrance
 	3748	2016-04-07 12:17:07	SQM	22.01	Up	clear	-7°	0%	Volcano Rim Parking Lot
 	3750	2016-04-07 12:25:56	SQM	21.95	Up	clear	-5°	0%	Fire Road End

[Add a new Observation](#)

Note: Some of your observation information is viewable by others.



Fig 20: Night sky social media post from the CAVO Facebook page

Restoration Leadership

The lighting retrofits made at the park are made publicly visible and interpreted on the Facebook page and in person at our visitor center or during star programs.

As seen on page 16, we completed sky brightness measurements with a Unihedron Sky Quality Meter (SQM). The SQM results are publicly visible on the Unihedron SQM database online. The results are also interpreted during star programs with live demonstrations. Visitors are explained how the SQM measures sky brightness and how we can use the data to document the evolution of light pollution in the area.

Social Media

CAVO is incorporating night sky operations into a rapidly growing social media platform. The park operates Twitter, Facebook and Instagram pages. Several posts from our social media pages have gone viral and reached anywhere from 50,000 – 100,000+ people. The park Facebook page alone is doubling in audience every year. Recent attempts to inform the public about our night sky activities have had great success.

The park often incorporates the use of GoPro cameras and editing software for education and interpretation efforts. We have made numerous high quality educational recreation videos for the park and other local recreation destinations. We plan to extend our GoPro efforts into the night sky with time lapses and distance education opportunities.

Fig 20:

Capulin Volcano National Monument
Published by Spencer Beard [7] · December 20, 2015 · 🌐

Starry Night Sunday:
Here at CAVO we have been busy pursuing designation from the International Dark Sky Association as a Dark Sky Park. We have been retrofitting all exterior lighting to meet specified regulations and documenting the quality of our night sky.
Starting in 2016, CAVO will host anywhere from 5-7 night sky interpretive events annually. Don't forget we allow 24/7 public access to the park for night sky viewing opportunities, and stay tuned for upcoming night sky ...
[See More](#)

Ranger Ty and Ranger Teresa: Replacing Incandescent Bulbs with LED Bulbs

Venus, Jupiter, & Mars Conjunction

492 people reached [Boost Post](#)

Like Comment Share

33 others

1 share

Write a comment ..

This is great.
Like · Reply · Message · December 20, 2015 at 11:40am

Yey ranger ty
Like · Reply · Message · December 20, 2015 at 10:28am

Fig 21: Current night sky products offered at the park store



Park Store

The Western National Parks Association (WNPA) is the vendor for all of our park store products. WNPA is a nonprofit education partner of the National Park Service all across the western U.S. WNPA develops products, services, and programs that enrich the visitor experience. Since 1938, WNPA has worked to connect new generations to parks in meaningful ways, all with one simple goal: create advocates who want to preserve and protect these special places for everyone, for all time.

We offer products in the store to encourage interest and engagement in the night sky world. CAVO is currently working with WNPA and other companies such as the David Chandler Company (Night Sky Star Chart) to expand our night sky product inventory to a full separate section.

The presence of night sky inventory in the store allows opportunities for rangers to make connections with visitors interested in astronomy. A simple demonstration on how to use a star chart in the field facilitates an opportunity to invite visitors to an upcoming star party or event at the park or in the surrounding area.

Capulin Guidelines

The lighting policies for Capulin Volcano National Monument (CAVO) abide to The National Park Service Management Policies 2006, The Guidelines for Outdoor Lighting for Dark Sky Places (GOL), and The New Mexico Night Sky Protection Act. By following the above guidelines CAVO intends to foster the reduction of light pollution, protect the nocturnal environment for wildlife, and provide a publicly accessible high quality dark sky site.

In order to follow the above guidelines, there are numerous decisions that must be made. Some of these decisions include what bulbs or fixtures should be installed, where they should be installed, or if they should even be installed at all. At CAVO, the first question when evaluating a lighting location should be “is the light necessary”? There are a few things to consider when determining if lighting is necessary.

- Is the light source necessary for human navigation?
- Is the light source necessary for basic human safety?
- Is the light source near other adequate light fixtures?

If the light source passes the first test, begin question round two.

- Is the wattage and correlated color temperature (CCT) of the light source as meager as practical?
- Is the spread of the light emitting from the light source controlled or able to be limited to a horizontal plane?
- Is the duration of the active period of the light source as short as practical?

If the light source passes round one and two, begin the final round.

- Is the light source adequate for human lighting needs?
- Is the light source adequate for safety or crime prevention?
- Does the light source have impact on human or environmental health?
- Does the light source have impact on wildlife or any other implications?

Human Lighting Needs

In some cases artificial lighting for nighttime uses is applicable. Humans require lighting at night for travel purposes such as driving vehicles, bikes, or walking around safely. In the case of Capulin Volcano, nighttime lights are

necessary for the safety of both vehicle and pedestrian traffic.

The dark night sky and desolation of the park causes some of the least visible conditions. In fact, there are certain nights at the park that you can extend your arm out in front of your face and be unable to see your hand. Considering such dark conditions, we do have night sky friendly fixtures installed in places that increase visibility for safely navigating around the park at night.

Human and Environmental Health

The contrast between day and night can have impact on the biological clock of humans and environmental factors. Biological clocks control our moods, alertness, sleep patterns, and numerous other physiological factors. Environmental presences such as plants and wildlife can also be similarly impacted by artificial nighttime lighting. The biological clock of plants is manipulated by the contrast of day and night. An array of wildlife depends on the quality nocturnal environment present at CAVO for nighttime foraging, reproduction, travel and communication.

Approximately 200 yards from the visitor center, there is a colony of Long Eared bats that roosts in a cave. Bats have arguably the preeminent species richness of any mammal order in the world. Considering the raw numbers of different bats there are in the world, they are a great indicator of ecological integrity or fluctuations.

Artificial lighting can have significant impact upon a range of bat behaviors including foraging, commuting, emergence, roosting, breeding, and hibernating. Artificial lighting can damage bat foraging habitat directly making an area unsuitable for foraging, or indirectly by severing commuting routes from roosts, through light spillage onto hedgerows and watercourses (Rasey, 2006).

Fig 22: Night sky management implications for Long Eared bats

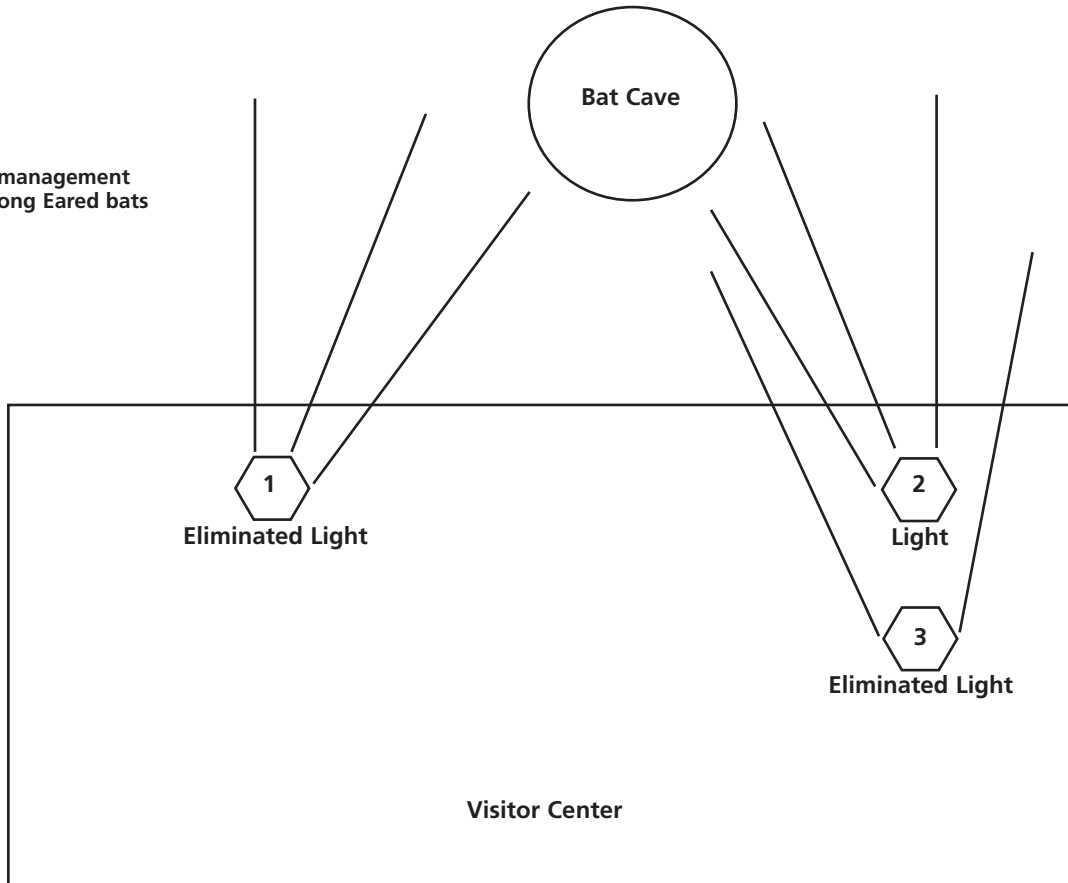

Long Eared bats

During the process of completing necessary lighting mitigations we have improved conditions not only for the night sky but for the bats as well. Lighting fixture #1 is a security light that was removed and will be replaced with a fully shielded fixture. Lighting fixture #2 is a front entrance light set on a timer. Finally, lighting fixture #3 has been deemed unnecessary and has been eliminated. As we continue to lay out the lighting management plans for years to come, external factors such as human and environmental health should be considered as valuable assets.

Selecting and Evaluating

Sustainability, efficiency, and cost are three factors that should be contemplated when selecting or evaluating lighting options for CAVO. When considering the sustainability of a lighting option the following questions should be asked.

- Is the light source going to be active for at least 10 years?
- How efficient is the light source and how much maintenance is required?
- Does the light source maximize economic and energy benefits?

Energy efficiency

Energy efficiency should be one of the first considerations when selecting or evaluating a light source. As mentioned earlier, light should only be used where necessary. An energy efficient lighting option doesn't necessarily mean it is a good option for preserving the dark sky. The level of illumination and color tone of the bulbs should be factored in as well. Proper selections and evaluations of lighting options at CAVO will help the park to reduce the overall carbon footprint and stay energy efficient for years to come.

Fig 23: Employee Housing energy budget

Energy Budget	LED	Incandescent
Estimated Lifespan (hours)	25,000	1,200
KWh used for 25,000 (hours)	250	1,500
Cost of Electricity (0.10/KWh)	\$25	\$150
Cost per bulb	\$10	\$0.78
Bulbs required for 25,000 hours of use	1	21
total cost	\$35	\$166.38
Savings for use of LED bulb (25,000 hours)	+ 131.38	
Savings for 7 LED bulbs installed in employee housing	$\$131.38 \times 7 = \919.77	

Costs

The costs associated with the annual energy consumption of the light source and maintenance and upkeep should be evaluated. At CAVO, we replaced numerous incandescent bulbs with LED bulbs. The average lifespan of the new LEDs is about 25,000 hours. The estimated energy costs for 25,000 hours using the LED replacements is 250 KWh of electricity. The average lifespan of the incandescent bulbs is about 1,200 hours. The estimated energy costs for 25,000 hours using the original incandescent bulb is 1,500 KWh of electricity.

As mentioned earlier, when selecting and evaluating a lighting option, the color tone, also known as the color scale of white light should be considered. The scale is measured in Kelvins in which the warm toned lights have lower values and the cold toned lights have higher values. In order to stay compliant with the Guidelines for outdoor lighting the light source should not exceed 4,000K. All of the new LED bulbs installed at the park are 3,000K.

Fig 24: Kelvin Color Scale. Lighting fixtures at CAVO have been brought to lower Kelvins (3000K).

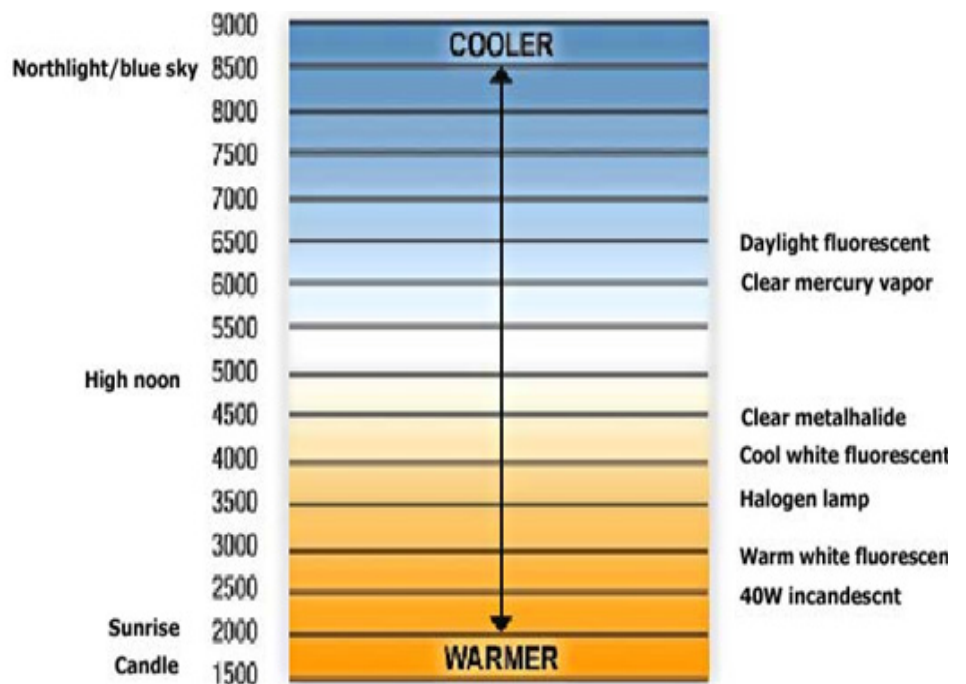

Outdoor Lighting Zones

Outdoor lighting is only necessary in a few select locations throughout the park. The outdoor lighting zone plan should be consulted before installing any new light sources. New light sources should only be installed in appropriate zones when the guidelines for outdoor lighting at CAVO have been met and there is a declared necessity for lighting at the location.

Fig 25: Outdoor Lighting Zone locations for the park

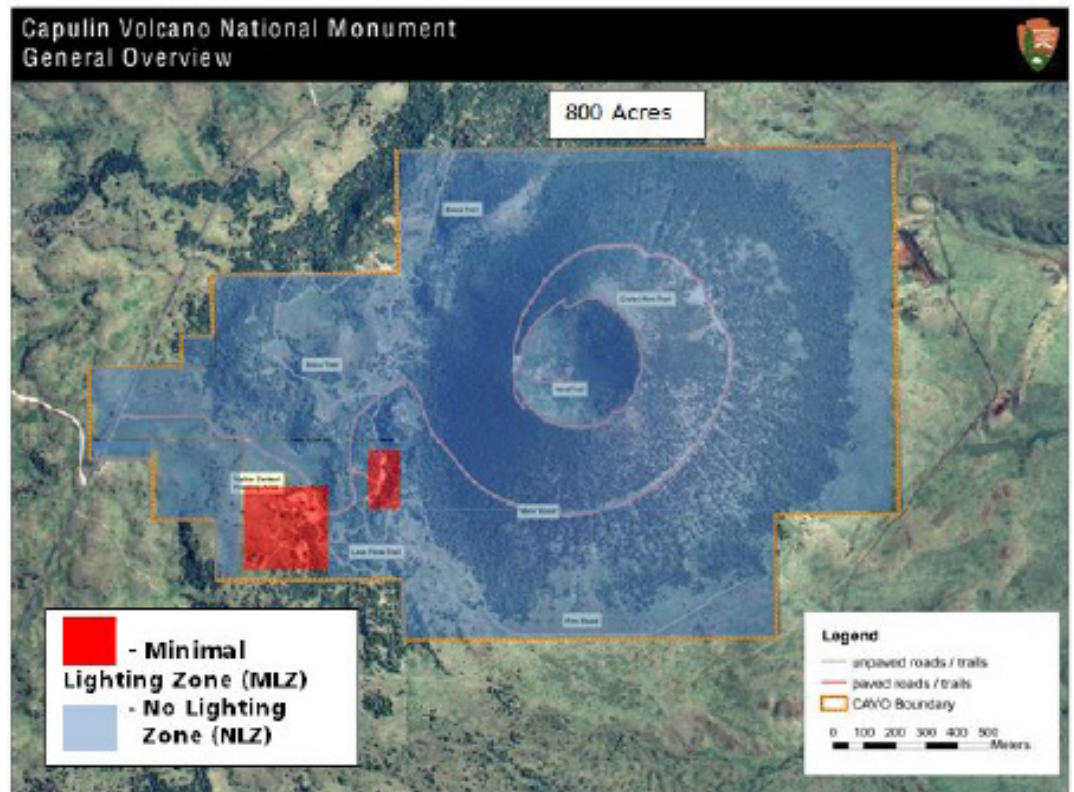

MLZ - Minimal Lighting Zone

The minimal lighting zones (MLZ) are set up around human developments. The two MLZ's should contain lighting sources only necessary for basic human safety and navigation. There should be NO permanent light sources installed in these locations that stay on continuously. Examples of acceptable reasons for lighting in these locations include entrances, exits, walkways, and security.

NLZ - No Lighting Zone

The no lighting zones (NLZ) are set up around undeveloped areas in which no permanent lighting fixtures are permitted.

Only temporary light sources are permitted in this zone given precautions are taken to minimize artificial light spread into other lighting zones and into the atmosphere. Examples of acceptable reasons for lighting in these locations include vehicle traffic, head lamps, and flashlights.

Night Sky Related Management Documents

Measuring Lightscares - NPS Natural Sounds and Night Skies



Photography by Arthur Schneider

National parks are preserves of biotic diversity and natural processes, as well as the “crown jewels” of America’s most scenic lands. Humans have gazed awe-struck into the universe for millennia, and ecosystems have adapted to the natural rhythms of the moon and stars.

In recent years light pollution has encroached upon lands that were once remote from large cities, such as national parks. Keeping such treasures unimpaired for future generations relies on science, reliable data, and sound judgment.

Efforts to protect naturally dark environments in our national parks are driven by NPS management policies. But before any action can be taken, park planners and managers need reliable data about a park’s existing lightscape.

Such baseline assessments become the foundation for monitoring programs to detect long-term changes and provide feedback for those who join the NPS in stewardship of natural lightscares.

Components of Sky Brightness

The night sky as we see it is a combination of both natural and human-caused sources of light. Natural light sources include moonlight, starlight from individual stars and planets, the Milky Way (also called galactic light or integrated starlight), the zodiacal light (sunlight reflected off dust particles in the solar system), and airglow.

Airglow is similar to a faint aurora (e.g., northern lights) and is caused by radiation striking air molecules in the upper atmosphere. Airglow is somewhat unpredictable, while the other sources of natural light can be predicted and modeled. Other intermittent sources of natural light include fire, lightning, and meteors.

The largest human-caused source of light is outdoor electrical lighting, but this can also include gas flares and other minor sources such as aircraft, automobiles, and satellites. While most natural light sources are emitted from great distances away, human-caused sources are relatively close. Light pollution includes both direct glare and skyglow (human-caused light scattered through the atmosphere).

In the highest quality skies, human-caused sources of light are less luminous than natural sources, and natural features of the night sky predominate. In a degraded natural lightscape condition, human-caused light is greater than that produced by natural sources. In some cases, many tens of times brighter.

Different Approaches

The opportunity to enjoy and appreciate natural lightscapes and starry night skies are dependent on the weather, the clarity of the air, and the amount of light pollution present. There is a range of methods for measuring the amount of light pollution:

- The visibility of certain celestial features can be used to make simple qualitative appraisals of the night sky. For example, the ability to see the Milky Way in the night sky (our own galaxy seen edge-on) indicates a moderate level of sky quality. These estimates can be done quickly by a dark-adapted observer but tend to be biased from one person to another. The most popular qualitative assessment is the Bortle Dark Sky Scale

- Another simple method is using “star counts.” A defined area of the sky, such as

the constellation Orion, is examined and the number of stars is either counted or the constellation is compared to a series of images. Each image shows an increasing number of stars; the more light pollution, the less contrast is afforded the observer and the less stars are seen. This estimate can be made by a dark-adapted observer with a basic understanding of the night sky in about 20 or 30 minutes. Star counts can also be biased from one individual to another and depend on the visual awareness and patience of the observer. Worldwide star counts allow the public to participate; one popular count is the Globe at Night program. You can try this yourself in your own neighborhood or park by exploring [How Dark Is Your Night Sky](#).

- A more sophisticated solution is to use a light sensor that measures luminance (the light falling upon a surface) or luminance (the brightness of a surface). These are typically photodiodes, but even a simple solar panel can be adapted to measure the relatively faint nighttime light striking it.

- These can be readily filtered and calibrated to estimate brightness as the human eye sees it, or can be tuned to what a specific wildlife species “sees.” A recent innovation of this type is inexpensive sky quality meters. These are similar to a photographer’s light meter but are tuned for measuring the luminance of the night sky as seen by human night vision. These provide a single quantitative measure of the night sky, typically pointed straight up at the zenith. The most common device is the Unihedron Sky Quality Meter.

- Another approach entirely is to put the camera in space onboard a satellite and look downward upon Earth’s surface. This method has been used to look at the global span of light pollution, trace the development of cities, and reconstruct the growth of light pollution over time.

Effects of Air Quality

An NPS scientist conducts an equipment check at sundown prior to a night of data collection with a CCD Camera at Great Basin National Park.

Photo by NPS/Kate Magargal. Kate completed the night sky quality report for CAVO.



The brightness and appearance of skyglow depends on atmospheric factors—chiefly moisture, air pollution, and dust particles. Clean, dry air scatters light pollution less, resulting in darker skies for observers close to the light source. However light travels farther through the air, so under good air quality conditions observers far from the light source may experience somewhat more light pollution. Poor air quality has the opposite effect, increasing light pollution close to the source and decreasing it at longer distance. However, poor air quality is seldom an advantage as it will also dim the natural features of the night sky.

Naturally occurring moisture in the air, such as clouds, fog, and haze, increase the scattering and reflectance of human-caused light sources at night. While cloudy conditions may naturally render the stars invisible, the interaction between clouds and light pollution should not be dismissed, as such conditions impact nocturnal habitats. As bright as light pollution on a clear night sometimes appears, the majority of stray light scatters freely into space. When clouds cover cities and towns, the bulk of stray light is reflected back down toward Earth's surface. This results in ground illumination sometimes being several times brighter under a cloudy sky than a clear sky.

Managing Lightscapes



National parks are lands with public treasures and expressions of our American values. They tell stories of the strength of our nation and its peoples, the American frontier wilderness, and the beauty and wonder of nature. Parks are places we can go to for rejuvenation, inspiration, and to delve into the larger world within which we live. Gazing upon the cosmos is just such an experience that deserves to be retained in our parks. Part of the NPS mission is to share these natural lightscapes with the public and to protect and restore them. Whether deep in a mountain wilderness area, at the edge of a historic battlefield, or beside the stone ruins of a 1,000-year-old culture, a natural lightscape is crucial to the overall integrity of parks.

The night sky can be one of the most awe-inspiring views we will ever experience. But the night sky and natural darkness are easily damaged and in many places are becoming lost in the glow of artificial lights. The protection of night skies has only recently been recognized as an important cultural, natural, and scientific resource by the National Park Service and the nation. At the turn of the century it was estimated that two-thirds of the country's population live where they cannot see the Milky Way (Cinzano, 2001). As starry skies have become rarer, park visitor interest in stargazing has increased sharply with corresponding economic benefits.

Many people seek protected lands, such as national parks and wilderness areas, to experience starry skies and dark nights. Maintaining the dark night sky above many national park units is a high priority for the National Park Service, and we actively seek partnerships to restore this heritage. The NPS strives to enhance the enjoyment of the resource for park visitors. Many visitors to national parks report “never seeing night skies this remarkable” or

had “forgotten what the Milky Way looked like”. The audience that is seeking out these experiences is increasing, and the NPS is proud to point a telescope skyward for them or guide them on a nighttime walk.

A critical step in the management of natural lightscapes is to measure and inventory the night sky condition. To address the measurement of this resource, the NPS Night Skies Team was formed to develop a system to measure and ultimately monitor changes to night sky brightness.

Since 2001 the NPS has systematically inventoried night sky quality in approximately 100 parks. The data show that nearly every park measured exhibits some degree of light pollution.

A growing pool of knowledge regarding ecological relationships with light, and the understanding of the impact light pollution has on human perception and experiences, combined with growing night sky data, will help the NPS to manage this resource for the benefit of parks and the people who visit them.

An essential management action is to work with neighboring communities to ensure that the protection of natural lightscapes is integrated into park and community planning. Basic principles such as using existing zoning to set appropriate outdoor lighting usage, following best management practices, and tracking progress can protect and even restore natural lightscapes.

References

Cinzano P., Falchi F. Elvidge C. 2001. World Atlas of Night Sky Brightness, *Monthly Notices of the Royal Astronomical Society*, 328, 689-707.

The NPS recognizes the importance of natural lightscapes and supports research and monitoring to protect this vanishing resource. The NPS will preserve, to the greatest extent possible, the natural lightscapes of parks, which are natural resources and values that exist in the absence of human-caused light. To prevent the loss of dark conditions and of natural night skies, the NPS will seek the cooperation of park visitors, neighbors, and local government agencies to prevent or minimize the intrusion of artificial light into the night scene of the ecosystems of park units. The NPS will not use artificial lighting in areas where the presence of the artificial lighting will disrupt dark-dependent natural biological resource components of a park, such as sea turtle nesting locations.

Light pollution is a relatively easy environmental problem to resolve. Solutions are immediate, effective, and often save money. Protecting night skies for ourselves and future generations only takes a bit of knowledge and effort in choosing night sky friendly outdoor lighting.

NPS Policy



“The National Park Service preserves unimpaired the natural and cultural resources and values of the national park system for the enjoyment, education, and inspiration of this and future generations. The park service cooperates with partners to extend the benefits of natural and cultural resource conservation and outdoor recreation throughout this country and the world.”



Online access
<http://www.nps.gov/policy/mp2006.pdf>

NPS Management Policies 2006

The 2006 management policy manual is the go to source of information for service wide policy and management implications. Adherence to policy is mandatory unless specifically waived or modified by the Secretary, the Assistant secretary, or the Director. The management policy manual specifically pinpoints several night sky related topics highlighted below.

4.1.4 Partnerships

The Service will pursue opportunities to improve natural resource management within parks and across administrative boundaries by pursuing cooperative conservation with public agencies, appropriate representatives of American Indian tribes and other traditionally associated peoples, and private landowners in accordance with Executive Order 13352 (Facilitation of Cooperative Conservation).

In addition, the Service will seek the cooperation of others in minimizing the impacts of influences originating outside parks by controlling noise and artificial lighting. . .

The above statements vouch for the dedication that we have in the NPS for pursuing and maintaining numerous lasting partnerships with resource management implications in mind such as the night sky.

4.10 Lightscape management

The service will preserve, to the greatest extent possible, the natural lightscape of parks, which are natural resources and values that exist in the absence of human caused light. The stars, planets, and earth’s moon that are visible during clear nights influence humans and many other species of animals, such as birds that navigate by the stars or prey animals that reduce their activities during moonlit nights.

Improper outdoor lighting can impede the view and visitor enjoyment of a natural dark night sky. Recognizing the roles that light and dark periods and darkness play in natural resource processes and the evolution of species, the Service will protect natural

darkness and other components of the natural landscape in parks. To prevent the loss of dark conditions and of natural night skies, the Service will minimize light that emanates from park facilities, and also seek the cooperation of park visitors, neighbors, and local government agencies to prevent or minimize the intrusion of artificial light into the night scene of the ecosystems of parks.

The Service will

- restrict the use of artificial lighting in parks to those areas where security, basic human safety, and specific cultural resource requirements must be met;
- use minimal-impact lighting techniques;
- shield the use of artificial lighting where necessary to prevent the disruption of the night sky, natural cave processes, physiological processes of living organisms, and similar natural processes.

The decision about whether or not to install artificial lighting in particular circumstances is left to the discretion of the superintendent and is made through the planning process.

9.1.3.4 Amphitheaters

Artificial lighting must be carefully directed and kept to a minimum, with due regard for natural night sky conditions.

9.3.2.1

When necessary for basic safety requirements, pathways and the exteriors of buildings and structures may be lighted. Such lighting will be energy efficient and shielded as much as possible so that visitors have the opportunity to experience the natural darkness and night skies.

National Park Service

Interim Outdoor
Lighting Guidelines
(DRAFT)



Developed by the
NPS Night Sky Team
Ver 1.0
1/30/2007

National Park Service Lightscape Management Plan

Purpose and Need The National Park Service has lacked service wide outdoor lighting guidelines. The need for better quality lighting and guidance to parks is clear by the variable quality of lighting installations found throughout several parks. There is also increased concern that park facilities are causing degradation of the nighttime environment. This lighting guideline is a simplified document intended to help parks immediately address lighting concerns, guide development, and provide a best management practice template to parks and park partners. The Night Sky Team will be developing a final document with finer, more detailed guidance, in cooperation with more NPS staff, Musco Lighting Company, the International Dark Sky Association, and other researchers and partners. CAVO intends to facilitate these guidelines in conjunction with others for the official park lightscape management plan.



Existing Standards and Codes

There are a variety of existing lighting standards, many of them in conflict and each focusing on variable aspects of lighting needs. Many of them are far more complex than what is suitable for a small or medium sized park seldom recognize the unique lighting needs of a national park, nor do they adequately address the recent rise in concern about light pollution. There are also other codes and standards currently being developed; these include the International Dark-sky Association (IDA) Model Lighting Ordinance, the New Buildings Institute Lighting Guidelines, and others. It should be noted that two national parks have made significant efforts on outdoor lighting— Yellowstone and Yosemite. Yellowstone has completed lighting guidelines while Yosemite has developed draft lighting guidelines that are currently undergoing additional revisions.

The interim lighting guidelines presented here are an amalgamation of several current and developing guidelines. They are intended to be used by most parks, although very large parks may find them not detailed enough or not addressing some unique situations. In cases where situations fall outside the realm of this document, further review and analysis, preferably through the NEPA process, is highly recommended. Thus, this document is designed to address 90% of the situations that arise in outdoor lighting.

It should be noted that the lighting recommendations contained herein produce illumination levels sometimes significantly lower than IESNA recommended practices. The trend in newer guidelines, such as ASHRAE 90.1 and the IDA MLO, is clearly

toward lower illumination levels, especially in darker ambient environments.

In most cases, parks have ambient light levels much lower than what was examined when many of these guidelines were developed. Lower ambient light levels often require less light, thus the disparity between IESNA standard and recommendations in this document.

Examples of existing codes and standards include:

- NFPA Codes and Standards, but not NFPA 5000
- NESC National Electrical Safety Code
- IEEE- Standards
- Illuminating Engineers Society of North America 9th edition (IESNA)
- UL – Underwriter’s Laboratory (Product Safety)
- Americans with Disability Act (ADA)
- ASRAE/IESNA 90.1 / 1999 (Energy Efficiency)
- LEEDS (sustainable building standards)
- EPA Energy Star
- New Buildings Institute Lighting Guidelines
- California Title 24 Building Code (Outdoor Lighting)
- International Dark-Sky Association (IDA) Pattern Lighting Code
- IDA Model Lighting Ordinance

Guideline Objectives

The objectives of this lighting guideline are to provide parks a planning strategy and best management practices for outdoor lighting. An important consideration in this document was balancing the need for safety with the sensitivity of the park nocturnal environment. The guideline focuses on off the shelf solutions, though development of new technologies like LEDs will soon allow parks to more precisely manage outdoor lights; however, for now only mainstream technologies have been included in this document. Simplicity of understanding and implementation of these guidelines was given greater weight than the details of lighting design, visibility research, and energy efficiency.

- Curtail and reverse the degradation of the nighttime visual environment and the night sky, including casual observation, astronomy, and air quality related values.
- Minimize glare, light trespass, obtrusive light, and artificial sky glow by limiting outdoor lighting that is misdirected, excessive, or unnecessary.
- Insure good neighbor lighting by minimizing light trespass.
- Help minimize suspected health risks to humans from adverse exposure to light at night.
- Help protect natural ecosystems from the damaging effects of night lighting.
- Permit reasonable and rational use of outdoor lighting for nighttime safety, utility, security, and productivity.
- Help to conserve energy and resources.
- Minimize maintenance and operating costs
- Provide some flexibility for architectural and artistic lighting within the above constraints

Scope

This guideline is intended to address outdoor lighting within park boundaries, including developed areas and concessions. It also may be applicable to other park lands or federal lands. It omits transportation right of ways where state and federal transportation codes may super cede park authority.

Complex facilities and lighting situations may require more guidance than is found here. In those cases, consultation with additional guidelines, lighting engineers, and the NPS Night Sky Team is encouraged.

Outdoor Lighting in a Park Setting

Virtually all national parks will have some need for outdoor lighting. As directed by the NPS Management policies, it is important to specify the need in every case of outdoor lighting and then choose a lighting design that

meets those needs. Too often lighting does not exist where it's necessary, the quality of the lighting is poor, or the brightness level is many times higher than what is required.

When less is better

Lighting engineer James Benya has done a substantial amount of research in Yosemite NP on appropriate lighting levels. His findings, not widely available, indicate that levels much lower than IESNA recommended practices are adequate and quite appropriate for a national park environment, even ones as populated as Yosemite Valley. These findings, combined with field experience retrofitting outdoor lighting and emerging ethics in the lighting engineering community have led to lighting design that finds a balance between the positive and negative attributes of light using higher performance designs at much lower illumination levels.

Human needs

Lighting serves both objective and subjective human needs. Objectively, light is used to provide adequate visual perception in low light. Although a healthy human eye is capable of adequate visual perception in very low light levels, full dark adaptation can take several minutes.

Additionally, the eye cannot easily transition from a bright environment (such as indoors) to a dark environment (such as outdoors at night). Thus outdoor lighting is needed to provide a minimal illumination level and ease high contrast transitions. The more detailed the visual task, the more light is typically needed. It is important to note here that human eyes function by reference to contrast, not absolute illumination.

At night, one can perceive that 10 foot-candles (a common measure of illumination) is twice as bright as 5 foot-candles, but it has not built in ability to quantify light amount.

If those same lights were gradually dimmed to 5 fc and 2.5 fc respectively, the eye may not be able to distinguish any change. Thus, the setting that a light fixture is in— the ambient light level, the lighting uniformity, the glare, and the transition a human experiences in that space are more important than an absolute illumination level. The thoughtless adherence to engineering standards without consideration of the setting is ill advised.

Ultimately, visual performance in an artificial lighting environment is more closely tied to lighting quality than lighting quantity (Lighting for Exterior Environments, RP-33-99).

Safety can be defined as freedom from danger, an objective requirement of lighting. Security can be defined as freedom from worry, a subjective aspect of lighting. Generally, lighting provides both, but gauging what type, amount, and quality of light is necessary for an adequate level of security is difficult (Lighting for Exterior Environments, RP-33-99).

“Too often, people associate lighter or brighter light with safer surroundings. It can be easily demonstrated that too much light or poorly directed light, causes a loss of visibility. For example, if a light is too bright, it prevents a person from discerning important detail because of the high brightness contrast or glare which causes a silhouette effect.” Quality park outdoor lighting may not appear to some visitors to meet their security needs at first glance, especially if they have come to associate a glary environment with security, but they should soon discover that such quality lighting has several advantages.

Transitions

Unlike an urban environment where one transitions from one lit area to another lit area, a park typically has a few isolated lit areas surrounded by naturally dark spaces. The ambient light level is much lower, expectations of amenities are different, there is an emphasis on self-reliance (for example, they may be carrying a flashlight), and transitions from one area to another are more important.

The low ambient light level allows less light to be used to provide visibility and security, provided glare is properly controlled. Additionally, some areas should not be lit, either by the desire of the park management, the visitor, or both.

Accessibility Standards

It is a requirement to provide accessible routes which meet standards set by the Americans with Disabilities Act (ADA). However, the ADA does not give guidelines on appropriate lighting levels for accessible routes. Lighting on accessible routes should follow the general guidelines stated here.

In order to accommodate people with impaired vision, lighting should maintain a continuous illumination, minimize glare, and not create a spotty effect.

Problems with Light

Light is not innocuous. It is an alteration of our environment like so many other human constructions, but it has received little attention as a significant environment change until recently. As seen from the many images of the Earth from space, outdoor lights have sprung up throughout most of the globe. The simple fact that light is visible from space, directly overhead shows how easily this human tool leaks out into the natural environment.

Light Pollution

The upward spill of light is often called light pollution. Dust, water vapor and other particles will scatter and reflect light that is emitted into the atmosphere creating sky glow. Light that escapes directly upward into the night sky is a major contributor to the loss of the dark night sky. Even light from a few fixtures can create an unnatural glow over a wide area (Yellowstone Lighting Guidelines 2005). Light from cities has been documented by the NPS as being visible from over 200 miles away. Even a long streetlight in the countryside can be seen for tens of miles. Most of the upward flux is from light escaping the fixture horizontally or upward.

A small fraction of light pollution, perhaps 15%, is caused by reflection off the ground and other surfaces. Direct up light is controlled by using full cut-off (sometimes called shielded) fixtures. This is thought to reduce the direct up light component to less than 25% of its former value. The reflected light component is controlled by using the minimal illumination level necessary. Minimizing this sky glow is essential in maintaining a natural nocturnal lightscape, and sets an important example for park visitors and neighboring communities.

Light Trespass and Glare

Light that shines horizontally from a fixture is not only a significant source of light pollution, but it is more apt to trespass into areas where light is not wanted. This low angle light is also the principle source of glare.

This glare light strikes the eye directly, and carries no visual information, unlike the reflected light from illuminated surfaces which carries information of depth perceptions, texture, detail, color, shape, etc. Glare can cause minor discomfort, or it can completely disable the eye's ability to see properly. Even when present in low levels, it will cause the pupil to constrict down, diminishing the remaining light in the visual field. Glare should be minimized in all circumstances to both improve the lighting quality and to minimize light trespass.

Solutions for this include using full cut-off or partial cut-off fixtures, aiming lights away from typical observation angles, aiming lights downward, increasing lighting uniformity, and reducing brightness levels of lights. It is important to note that interior lights may shine outside the structure (especially common in clear-story windows in restrooms) causing the same effect as a poor quality outdoor light.

Ecological and Health Impacts

“Every year there is more research suggesting that artificial light is affecting the natural environment and the biological rhythms of both plants and animals that are critical to native habitat and natural evolution. Effects of artificial light on wildlife can cause avoidance or attraction behavior with diverse and significant consequences that not only affect the species themselves but those on which they prey and those that prey on them.

Research to date has concentrated on the effects of artificial light on birds and insects, but there is evidence that light affects larger animals. Mammals that travel long distances to find food or mates, such as mountain lions, may avoid links between natural areas if the areas emit artificial light” (Yellowstone Lighting Guideline 2005).

Because the scientific literature is relatively sparse on this topic, there is frequently no species specific information available. However, there are some generalities that are useful guides. Nocturnal predators are particularly affected by artificial light, either positively or negatively, which can have resultant impacts on their prey species.

Birds, many of which migrate at night, are

particularly prone to disorientation by artificial lights. Certain biomes are believed to be more sensitive. These include wetland and ponds, shorelines, alpine areas, and open country such as deserts and prairies.

The NPS is currently working with researchers to provide lighting guidance as it relates to wildlife and these will be incorporated in the finalized document. Finally, humans are animals too, and there is a solid body of research linking artificial light at night (as well as decreased light exposure during the day) to a myriad of health problems.

Sustainability

Outdoor lighting is the last appliance that has received so little energy efficiency scrutiny. Though the different types of lamps are well studied (for example a 4x energy savings is realized by replacing a traditional light bulb with a compact fluorescent), the question of what type of fixture, how much light, and if an area should be lit at all has not seen much discourse. It is estimated that the portion of light that shines upward and creates light pollution represents \$2 to \$5 Billion annually in the US. Thus, saving our night skies can have tremendous economic and energy benefits.

Designing for efficiency

The basic tenants of efficiency are to use light only when and where it is needed, and if needed, use the most efficient light source that meets the task requirement.

Lamp technology has evolved much, and efficiencies can be improved 2x-5x by using modern lamp types. Reducing light levels are a viable solution if illumination can be reduced while still meeting the task, yielding similar efficiency gains. Full cut-off shielding reflects all that light that would go into space downward, further improving efficiency. And finally smart technologies, from the very basic timer or motion sensor, to elaborate computer controlled lighting and LED lamps can further improve efficiencies.

Maintenance Cost

What is energy efficient is almost always cost efficient. But another aspect of cost reduction is maintainability. Lighting design should include workload estimates related to upkeep.

Capital cost should be compared with energy efficiency and maintenance intervals to get a true picture of the cost of lighting. All too often, lighting choices are made based only on fixture cost. A \$40 yard blaster light can be purchased at a hardware outlet, compared to a high end fixture (or luminaire as they are often called) costing \$400. However, if the yard blaster is 175 watts and the full cut-off luminaire is 18 watts, the capital cost will be offset by energy savings in 4 years. Over a 20-year fixture lifetime, the difference becomes \$1200.

A similar comparison can be made with lamp lifetimes. A typical incandescent lamp will last about 1500 hours, compared to 10,000 hours for a compact fluorescent lamp (CFL). The old fashioned light bulb will be changed 6 or 7 times before the CFL burns out, more than making up for its higher initial cost.

Design

Lighting is an important element in architecture and landscapes. It can emphasize spaces, highlight the landscape, and serve purposes beyond the basic need for visibility.

Just as the NPS has graphic identity guidelines and a park may have certain sign design standards, the lighting too may be part of such a design vision.

Design issues can include pole height and pole spacing, fixture appearance, illumination pattern, light level, or light color to name a few.

Lighting is often an important architectural element; however, architectural and artistic lighting may not be appropriate in parks. Washes of light on building, lit statues, dramatically lit boulders or waves are often not appropriate and cannot be justified under the current management policies when the purpose is merely vanity.

Lamp Color

One element that receives much attention is the color of the light. Different lamp technologies, such as High Pressure Sodium (HPS) or Low Pressure Sodium (LPS) produce yellow light. This monochromatic or color biased light cannot render colors properly (these are often described as having a low color rendering index).

Many feel that this light has an industrial character. Research indicates that less light is needed (and therefore less energy) for the human eye to see efficiently with a white (blue/green) light source than with a more yellow light source. However, HPS and LPS lights are more efficient than white light sources such as Metal Halide (MH), Mercury Vapor (MV), or even Compact Fluorescent Lamps (CFL), producing more lumens per watt. They are also believed to be less impacting to nocturnal wildlife. For example, LPS is often used on turtle nesting beaches with good success. Additionally, the yellow lights scatter much less in the atmosphere and are 2.5x (HPS) to 5x (LPS) less interfering with human night vision than white light.

This is an important factor in maintaining dark night skies. The color rendering abilities and improved visibility of white lights are at odds with their lower energy efficiency, wildlife impact, and night sky impact, causing frequent professional disagreement. The bias of this guideline is to use yellow lights sources as a default when available unless the need for better color rendition is demonstrated.

Historic Integrity

Historic structure and cultural landscapes have particular lighting needs that may not be addressed in this document. Both the light fixtures themselves and the character of the light they produce are of concern. Often there is too much emphasis on selecting fixtures that look of the appropriate period, while the nighttime scene is neglected but just as important to the historic integrity.



Lighting Guidelines

Approaches

There are several ways to define lighting. They can be divided into two categories— prescriptive where the type, size, lamp, etc. of the light is defined, or performance where the resultant illumination levels are defined. The latter is more accurate, but requires computer modeling and photometric data on each light fixture. Because so many of the fixtures used in parks are low cost ones without photometric or custom designs, and lighting expertise to run computer models is rare, a prescriptive approach is taken here. There are several aspects of lighting design that can be controlled and defined. The ones chosen to be prescribed in this guideline are limited for simplicity and bolded.

Prescriptive Parameters	Performance Parameters
Lumens	Illumination (minimum, avg, max)
Watts	Glare or Glare Ratio
Power density	Uniformity (average:minimum)
Lumen density	Uplight and light distribution
Pole Spacing	Spill light/light trespass
Pole height	Transition
Fixture shielding and aiming	

Zones

Two zones should be established in a park. One zone should be a zone where permanent lighting fixtures are not permitted. The second zone should be where permanent outdoor lighting is allowed within the guidelines.

Typical Lighting Zone	Description
No Outdoor Lighting	All wildland areas and viewpoints
Lighting Allowed	Developed facilities area

Planning and Compliance

Lighting has been considered a routine maintenance practice and has therefore escaped much of the planning and compliance process. This has led to the current situation where light pollution in parks is not only the result of lights in distant cities, but is caused by the park itself. The 2006 Management Policies clearly indicate lighting should be part of the planning and compliance process. This interim guideline was intended to ease this process and provide more autonomy to facility and concession managers when working within the guideline.

Cumulative Effect

Though cumulative effect has not been directly addressed in the guideline, it is recommended that parks not only consider the specifications of an individual light, but what the total impact of a new or expanded light project would produce. Though these guidelines mitigate negative impacts to the maximum practical extent, dramatic increases in installed lights will have a noticeable impact. Fortunately, for many parks with an installed base of mixed quality lights, offsetting impacts from new projects is fairly easily done by retrofitting additional poor quality lights.

Lighting Applicability

Where there is an expectation by the visitor or employee of darkness and people are generally prepared for darkness (either through dark adaptation or carrying their own flashlight), lights should not be installed.

Lights should be installed as an illumination transition on commonly used building egress points, where outdoor work may be done at night, where critical information is posted, to draw nighttime visitors to important information or safety point (such as a phone booth or visitor center entrance), where there is a demonstrated need for protection of assets, where there is an identified safety hazard, or where facilities are commonly used at night (such as a laundry room in residence area).

When choosing whether to light an area, it is important to consider the cumulative effect of the action as well as if the illumination will be successful in its desired function. It is also important to consider illumination transitions; an isolated light may effectively light a small area but will render the surrounding dark area less visible. Security lighting where no patrols exist (such as a remote storage yard) is often counterproductive, inviting crime without the opportunity to intercede.

Requirements - Exterior Lighting

All permanent exterior lighting shall be fully shielded and use the proper illumination level.

When fixtures are articulating, such as PAR flood lamps, they should have directional shields, should be aimed within 45 degrees of downward, and should not illuminate areas outside the intended target.

Special Use Lighting

Un-shielded and partially shielded fixtures are permitted for low voltage LED pathway lights, under-canopy lights at phone booths, and other guidance lighting provided they are ≤ 7 watts each.

Prescriptions

Maximum Lamp Lumens

7000 lumens is the maximum allowable lamp output (except for emergency lighting). In most cases, 500-1500 lumens will be sufficient.

Pedestrian Walkways	
Maximum Lamp Lumens	1000
Recommended Light Types	Low voltage LED guidance lighting or very low lumen fully shielded lamps. Higher illumination steps or even ground.
Recommended Illuminated Area	Pathway and area immediately adjacent to path.
Recommended Duty Cycle	Timer for operation during frequently used times.

Residential Surrounds (Private Buildings)	
Maximum Lamp Lumens	2000
Recommended Light Types	CFL 500-100 lumens
Recommended Illuminated Area	Light dispersal limited to residential boundary.
Recommended Duty Cycle	Mix of switches (for occasional use), and motion sensors.

Building Egress Points (Public and Staff Buildings)	
Maximum Lamp Lumens	3000
Recommended Light Types	CFL 500-1500 lumens. Forward throw fully shielded fixture.
Recommended Illuminated Area	Egress point and surrounding approach. Transition from lit to dark area should be.
Recommended Duty Cycle	All night operation at critical safety, frequently used, and visitor contact points. Motion sensors or user accessible switches for other tasks.

Parking Lots	
Maximum Lamp Lumens	7000
Recommended Light Types	Not generally recommended. If required, light with LPS or HPS lamps of 3500-7000 lumens (depending on pole height).
Recommended Illuminated Area	Portion of parking lot used at night.
Recommended Duty Cycle	Switched with timers to prevent all-night operation.

Safety and Work Areas (Fueling Station, Generator Bay, etc)	
Maximum Lamp Lumens	7000
Recommended Light Types	CFL of 1200-3000 lumens for most applications. Fully shielded lights.
Recommended Illuminated Area	Only immediate work area.
Recommended Duty Cycle	User controlled switches or power-interrupt sensor.



Lamp Selections

The standard lamp shall be a cold-start compact fluorescent lamp (CFL), ideal for its high energy efficiency and range of wattages. These should produce less disruption to the nocturnal species and human experience of the night than a 70-watt High Pressure Sodium (HPS) lamp provided the CFL lamps are 26 watts or less. Incandescent lamps may be used with motion sensor lights. Lighting requiring more than 2000 lumens should use HPS lighting.

Other Situations

Sign Lighting

Internally illuminated signs should be light lettering on a dark background and should not be lit after the related facility has ceased operation for the night. Externally illuminated signs should be lit from the top downward with fully shielded or partially shielded fixtures and should use the minimum amount of light necessary. No specific guidelines are established in this interim guideline, however it is recommended that sign lighting only be employed where it is clearly necessary and that luminance be limited to approximately 1000 lumens or less per side per modest size sign, depending on viewing distance and ambient light level.

There is a growing misconception that flags should be up all night and should be lit. At active federal sites there is little excuse to not honor the flag daily by its raising and lowering. The Patriot Act of 1976 requires nighttime flags to be lit, but does not in any way indicate patriotic preference for leaving the flag up during darkness. Recently some top-down lighting solutions for flags have come to market. This will allow full compliance of flat lighting if there is such a need.

Exempt lighting

- 1) Where OSHA states that specific lighting levels are necessary for work situations these are considered exempt from the Lighting Guidelines. However, although the lighting levels for the actual work environment must meet OSHA requirements all measures outlined in this document must be taken to exercise best energy practices and shield the light from the surrounding environment.
- 2) Emergency lighting is exempt from these controls provided it is not used for routine maintenance or scheduled functions. Typically, emergency lighting is used once a year or less and is necessary for human safety in emergency or unforeseen circumstances.
- 3) Traffic safety warning lights and speed indicators are NOT automatically exempt but should be considered on a case by case basis.
- 4) Holiday lighting provided they are only operation during the holiday period

"If the Stars should appear one night in a thousand years, how would men believe and adore... But every night come out these envoys of beauty, and light the universe with their admonishing smile."

Ralph Waldo Emerson

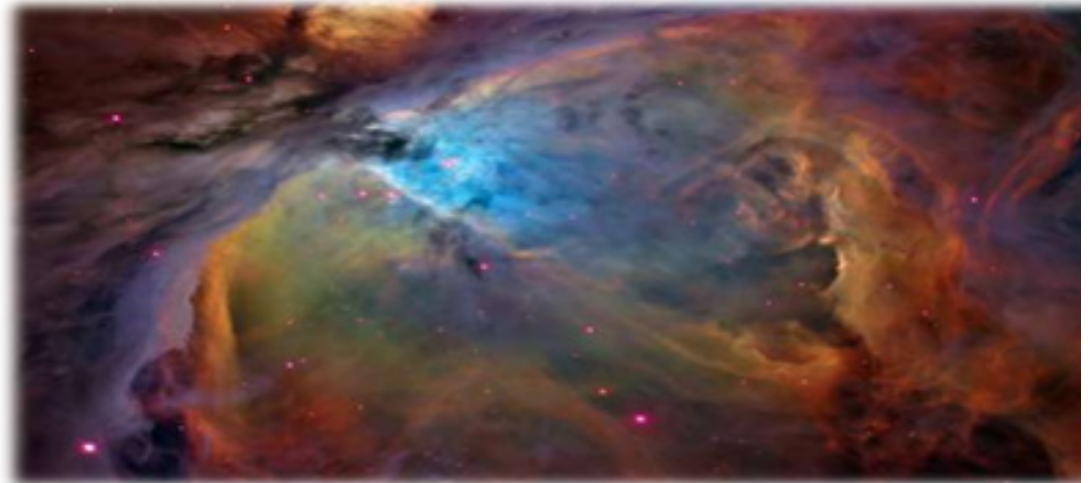

Lamp Characteristics

Lamp types should be carefully chosen. Proper lumen output, efficiency, and spectral characteristics should be key elements in the decision. Other factors to consider should be lamp life, lamp availability and cost, aesthetics, and appropriateness.

The following are allowed under these guidelines when specifically permitted.

Table 6 – Typical lamp characteristics

Lamp	Watts	Lumens (initial output)	Lumens/watt (efficiency)	Lifetime (hours)	Color Rendering
A-Lamp Incandescent	40	500	12	1000	100
	60	850	15	1000	100
	100	1600	16	1000	100
Compact Fluorescent	7	400	57	10000	85
	13	775	60	10000	85
	23	1400	60	10000	85
	26	1650	65	10000	85
	42	2800	65	10000	85
Metal Halide	39	2800	72	6000	85
	50	3700	75	6000	85
	100	7500	75	6000	85
	150	10500	70	6000	85
High Pressure Sodium	35	2200	50	24000	40
	50	3700	60	24000	40
	70	6200	75	24000	40
	100	8000	80	24000	40
	150	14500	85	24000	40
Low Pressure Sodium	18	3800	150	18000	0
	35	6800	150	18000	0
	90	15300	150	18000	0

Note- High color rendering combined with total brightness typically results in higher impact to nocturnal environment

Appendices

Glossary

Fully shielded - a fixture that throws light downward only and in which the lamp itself is shielded so that it cannot be seen except from under the fixture.

Full-cut-off – a fixture that is fully shielded and has virtually no part (or a negligible amount) of the fixture lit below the horizontal.

Cut-off - is a fixture that shields upward light causing light to shine both downward and sideways only.

Luminance – is the quantity of light reflected or emitted toward an observer, i.e., the light an observer sees.

Illuminance – is a measure of light in either foot-candles (imperial) or lux (metric). Technically described as flux density per unit area.

Brightness – is a subjective sensation to measured luminance.

Glare –

- Disability Glare (veiling luminance) – is stray light scattered within the eye reducing the contrast of the image.

- Discomfort Glare – is high contrast or non-uniform distribution of luminance in the field of view.

- Nuisance or annoyance glare – is not quantified but is basically annoying light such as the light shining in the window.

Visual Adaptation to Light –

- Photopic Vision – is the eye’s response at high light levels when cones are used to determine color and to focus on objects.

- Scotopic Vision – is the eye’s response at low light levels such as moon-light when rods are used. Peripheral vision is strong and everything appears in shades of gray.

- Mesopic Vision – is a combination of photopic and scotopic vision.

- All definitions “Lighting for exterior environments” IESNA

Night Sky Protection Act
CHAPTER 74. ENVIRONMENTAL IMPROVEMENT
ARTICLE 12. NIGHT SKY PROTECTION

74-12-1. Short title.

This act [74-12-1 to 74-12-10 NMSA 1978] may be cited as the "Night Sky Protection Act".

History: Laws 1999, ch. 197, & 1.

74-12-2. Purpose.

The purpose of the Night Sky Protection Act [74-12-1 to 74-12-10 NMSA 1978] is to regulate outdoor night lighting fixtures to preserve and enhance the state's dark sky while promoting safety, conserving energy and preserving the environment for astronomy.

History: Laws 1999, ch. 197, & 2.

74-12-3. Definitions.

As used in the Night Sky Protection Act [74-12-1 to 74 -12-10 NMSA 1978]:

A. "outdoor lighting fixture" means an outdoor artificial illuminating device, whether permanent or portable, used for illumination or advertisement, including searchlights, spotlights and floodlights, whether for architectural lighting, parking lot lighting, landscape lighting, billboards or street lighting; and

B. "shielded" means a fixture that is shielded in such a manner that light rays emitted by the fixture, either directly from the lamp or indirectly from the fixture, are projected below a horizontal plane running through the lowest point on the fixture where light is emitted.

History: Laws 1999, ch. 197, & 3.

74-12-4. Shielding of outdoor light fixtures.

All outdoor lighting fixtures installed after January 1, 2000 shall be shielded, except incandescent fixtures of one hundred fifty watts or less and other sources of seventy watts or less.

History: Laws 1999, ch. 197, & 4.

74-12-5. Nonconforming light fixtures.

A. In addition to other exemptions provided in the Night Sky Protection Act [74-12-1 to 74-12-10 NMSA 1978], an outdoor lighting fixture not meeting these provisions shall be allowed, if the fixture is extinguished by an automatic shutoff device between the hours of 11:00 p.m. and sunrise.

B. No outdoor recreational facility, whether public or private, shall be illuminated after 11:00 p.m. except for a national or international tournament or to conclude any recreational or sporting event or other activity conducted, which is in progress prior to 11:00 p.m. at a ballpark, outdoor amphitheater, arena or similar facility.

History: Laws 1999, ch. 197, & 5.

74-12-6. Use of mercury vapor lighting fixtures.

No new mercury vapor outdoor lighting fixtures shall be sold or installed after January 1, 2000.

History: Laws 1999, ch. 197, & 6.

74-12-7. Exemptions.

A. The following are exempt from the requirements of the Night Sky Protection Act [74-12-1 to 74-12-10 NMSA 1978]:

- (1) outdoor lighting fixtures on advertisement signs on interstates and federal primary highways;
- (2) outdoor lighting fixtures existing and legally installed prior to the effective date of the Night Sky Protection Act; however, when existing lighting fixtures become unrepairable, their replacements are subject to all the provisions of the Night Sky Protection Act;
- (3) navigational lighting systems at airports and other lighting necessary for aircraft safety; and
- (4) outdoor lighting fixtures that are necessary for worker safety at farms, ranches, dairies, feedlots or industrial, mining or oil and gas facilities.

B. The provisions of the Night Sky Protection Act are cumulative and supplemental and shall not apply within any county or municipality that, by ordinance or resolution, has adopted provisions restricting light pollution that are equal to or more stringent than the provisions of the Night Sky Protection Act.

History: Laws 1999, ch. 197, & 7.

74-12-8. Construction industries division; duties.

The construction industries division of the regulation and licensing department shall review the outdoor lighting provisions in the uniform building codes used in New Mexico and make recommendations for appropriate changes to comply with the provisions of the Night Sky Protection Act and shall permit and inspect, to the standards set forth in the Night Sky Protection Act, all construction of and on state-owned buildings that is subject to permit and inspection under the Construction Industries Licensing Act [60-13-1 NMSA 1978].

History: Laws 1999, ch. 197, & 8; 2001, ch. 151, & 1.

74-12-9. Costs of replacement; recovery.

If public utilities are required pursuant to the provisions of the Night Sky Protection Act [74-12-1 to 74-12-10 NMSA 1978] or by local government ordinances to accelerate replacement of lighting fixtures, the cost of such replacement shall be included in rates approved by the public regulation commission.

History: Laws 1999, ch. 197, & 9.

74-12-10. Violations; penalty.

Any person, firm or corporation violating the provisions of the Night Sky Protection Act [74-12-1 to 74-12-10 NMSA 1978] shall be punished as follows:

- A. for a first offense, the offender may be issued a warning; and
- B. for a second offense or offense that continues for thirty days from the date of the warning, twenty-five dollars (\$25.00) minus the replacement cost for each offending fixture.

History: Laws 1999, ch. 197, & 10.

74-12-11. Enforcement.

In order to promote the purposes of the Night Sky Protection Act and to provide uniform minimum outdoor lighting standards throughout the state, the construction industries division of the regulation and licensing department shall enforce the Night Sky Protection Act as it pertains to public buildings subject to permit and inspection under the Construction Industries Licensing Act and each political subdivision of the state shall fully enforce the provisions of the Night Sky Protection Act.

History: Laws 2001, ch. 151, & 2; repealed and new & 74-12-11 NMSA 1978, as enacted by Laws 2009, ch. 79, & 1.

Letters of Support

United States Department of the Interior



IN REPLY REFER TO:

NATIONAL PARK SERVICE
Capulin Volcano National Monument
46 Volcano
Capulin, NM 88414
575-278-2201



February 29, 2016

**International Dark Sky Association
Board of Directors
3223 North 1st Ave.
Tucson, AZ 85719**

As the superintendent of Capulin Volcano National Monument (CAVO), I strongly support the designation of our park as the newest member of the dark sky places program. Our park is home to some of the most remarkable night sky spectacles in the United States and we have the numbers to back it up. CAVO allows unrestricted public access for night sky viewing opportunities and will be hosting several programs annually.

Visitors at CAVO continue to have opportunities to experience stargazing with the use of telescopes, hiking after dusk, or viewing from the top of the volcano. As unnecessary light increasingly floods the skies in the larger towns to the north and south of our location such as Denver and Albuquerque, visitors are astonished by an escape to the authentic dark skies encompassing northeastern New Mexico.

Policies followed by our park at the national, state, and agency levels limit the use of artificial lighting and recognize the night sky as a fundamental resource to be managed and as an interpretive theme. CAVO has developed a park specific lighting policy including facility lighting management, outdoor lighting zones, and future guidelines and plans. Lighting retrofit effort put forth by park staff have eliminated 12,722 unnecessary lumens from exterior and interior lighting directly impacting the nighttime environment. Plans included in our application have been made to continue to improve these efforts in coming years.

The Staff at CAVO are committed to keeping our dark skies dark, allowing public viewing opportunities, and expanding our horizons to increase the radius of night sky awareness. Please consider Capulin Volcano National Monument as a premier candidate to be the next International Dark Sky Park.

Sincerely,

Randy Bilbeisi
Superintendent
Capulin Volcano National Monument
46 Volcano
Capulin, NM 88414

State of New Mexico
Energy, Minerals and Natural Resources Department

Susana Martinez
Governor

David Martin
Cabinet Secretary

Brett F. Woods, Ph.D.
Deputy Cabinet Secretary

Christy Tafoya, Division Director
State Parks Division



Sept. 3, 2015

To the IDA Board of Directors:

I'm writing to support the application by Capulin Volcano National Monument (CAVO) to become an International Dark Sky Park.

As a regional interpretive ranger for NM State Parks, I routinely provide night sky programs for state parks in Northeastern New Mexico. I use an eight inch Orion (Dobs) telescope, as well as a laser pointer for constellation stories.

I am based at a state park near CAVO, and I have partnered with CAVO rangers on astronomy programs atop Capulin Volcano. The night sky there is excellent, since the volcano is far from any large communities and light pollution is almost non-existent. In addition, because of the unobstructed view from on top of the volcano, the night sky is visible for 360 degrees.

I believe Capulin Volcano National Monument would make a wonderful International Dark Sky Park.

Sincerely,

Patricia H. Walsh

Patricia Walsh
Regional Interpretive Ranger/ Northeast Region
New Mexico State Parks
575-445-5607

October 19, 2015

Edwin Spencer Beard VIII
Capulin Volcano National Monument
46 Volcano Rd.
Capulin, NM 88414

To whom it may concern:

We are writing in support of the nomination of the Capulin Volcano National Monument as an International Dark Sky community. The Capulin Volcano National monument is located in a pristine section of the southwest United States where the high altitude and dry air combine to create ideal conditions for observing the night sky. Nowhere is the panorama of the night sky more spectacular than from the truly dark skies of Capulin.

The location of the Capulin Volcano National monument is within a convenient distance to population centers in the Colorado front range, northern New Mexico, Kansas, Oklahoma, and Texas. We believe that preserving the dark skies at Capulin will certainly increase the interested visitation to this wonderful National Monument increasing the value of the resource to region.

We also recognize that Capulin is located in sparsely developed territory where the emergence of unchecked light pollution would be an especially disruptive beacon to local and migrating wildlife. The efforts they have taken to minimize their stray light impact are certainly a benefit to the ecology of this region.

In summary, we feel that the designation of Capulin Volcano National Monument as a Dark Sky Site would recognize all of their efforts to grow responsibly and preserve the public's access to a valuable resource, the night sky. Additionally, the designation will help bring attention to the positive example they are setting for the public and private development in general. Finally, we believe that the value of the designation will quickly become apparent and that the efforts to maintain Dark Sky status will help guide development of the monument and the local area into the future.

Sincerely,

A handwritten signature in blue ink, appearing to read "Dita Darrah".

Dita Darrah
President David Chandler Company, Inc.



The Mandala Center

www.mandalacenter.org

PO Box 158 Des Moines, NM 88418

575.278.3002

November 11, 2015

Board of Directors
International Dark-Sky Association
3223 North First Ave.
Tucson, AZ 85719

Dear IDA Board of Directors.

I am writing this letter in support of Capulin Volcano National Monument's designation as a Dark Sky Park.

Capulin Volcano is located 15 miles from the Mandala Center, a retreat center in northeastern New Mexico. This is a very rural area, free of the light pollution that affects so many communities. Our guests often comment on the beauty of the area and how this is one of the few places where they've had the opportunity to truly view the night sky.

The Mandala Center has partnered with Capulin Volcano to sponsor various events and have found their staff to be very knowledgeable and truly committed to protecting our environment. A dark sky designation would further enhance their ability to provide educational opportunities to the public.

I believe Capulin Volcano National Monument is a perfect candidate for a Dark Sky Park designation and ask the IDA board to strongly consider their nomination.

Respectfully,

Karen Brown

Executive Director

The Mandala Center

575.278.3002 - fax 575.278.3001 - information@mandalacenter.org

www.mandalacenter.org



United States Department of the Interior



NATIONAL PARK SERVICE
INTERMOUNTAIN REGION
12795 West Alameda Parkway
P.O. Box 25287
Denver, Colorado 80225-0287

IN REPLY REFER TO:
IMR-RSS-NR (1242)

NOV 19 2015

Board of Directors
International Dark-Sky Association
3223 North First Avenue
Tucson, Arizona 85719-2103

Dear IDA Board of Directors:

The National Park Service Intermountain Region's Natural Resources Division is pleased to support Capulin Volcano International Dark Sky Park (IDSP) nomination. Capulin Volcano National Monument is located in an accessible, but relatively unpopulated area of northeastern New Mexico. It was established by President Woodrow Wilson in 1916 to preserve a unique, 1300 foot volcanic cinder cone. The accessible summit offers spectacular panoramic views of the entire night sky in every direction. Although the dark skies of this area have already been recognized at Clayton Lake State Park, we believe the value that Capulin Volcano would offer as a designated IDSP is just as substantial.

Due to the unique panoramic view at the volcano's summit, the park has become a recognized destination for astronomy enthusiasts in multiple states, including the Oklahoma City Astronomy Club. Capulin Volcano's role in dark skies protection is important not only for the education and outreach efforts that occur at the park, but also for supporting protection of nocturnal ecosystems and the night sky resource in this region, pursuant to the New Mexico Night Sky Protection Act.

The Intermountain Region's Natural Resources Division has been a member of the International Dark Sky Association (IDA) since July 2011. We appreciate the efforts of IDA and the opportunity to join the worldwide network of committed individuals who care deeply about preserving the beauty and heritage of our night skies. We fully support the efforts of Capulin Volcano National Monument as they seek designation as an IDSP. We believe its nomination and ongoing efforts to conserve dark skies will benefit park visitors, nearby communities, and future generations. Should you have any questions, please contact Randy Stanley at 303-987-6890.

Sincerely,

Patrick Malone
Assistant Regional Director, Natural Resources Division

cc: Peter Armato, Superintendent, Capulin Volcano National Monument
Kurt Frstrup, Science & Technology Branch Chief, NSNSD, WASO



United States Department of the Interior

NATIONAL PARK SERVICE
Southern Plains Inventory and Monitoring Network
23501 County Rd. 111.3
Model, CO 81059

IN REPLY REFER TO:

October 19, 2015

International Dark-Sky Association
Board of Directors
3223 North First Ave.
Tucson, AZ 85719

Dear Sirs and Madams:

I am writing on behalf of Capulin Volcano National Monument, and in particular the quality of the night skies at this monument. As program manager of the Southern Plains Network of Parks, I oversee the monitoring of natural resources in parks throughout the Southern Great Plains. As part of our program, we have been conducting Natural Resource Condition Assessments at parks throughout this region which summarize the condition of resources important for each park. Included in this assessment is the condition of the night skies using data collected with a wide field CCD camera by our NPS Night Skies Program, as well as ancillary sources of information (full report available upon request).

I am writing because the night skies at Capulin Volcano, while not completely dark, are among the very best for this region. In fact, I have not seen darker skies within the Southern Great Plains. This monument offers some of the best night sky viewing within several states and should be recognized for its value. The staff at Capulin Volcano NM have already begun to take advantage of this opportunity through their educational and interpretive programs, and recognition of this site would only enhance these opportunities. Thus, I hope that you will consider recognition of this important site as part of a network of the few areas where dark skies remain as part of our nation's treasured resources.

Sincerely,

Robert Bennets, PhD
Program Manager
Southern Plains Network of Parks

Letter of Support for Capulin Volcano National Monument

To: IDA Committee

I have worked as a volunteer at Capulin Volcano National Monument for several years as a Night Sky Astronomer. My background is Astronomy and I have taught that subject and physics for 40 + years at Amarillo College, and several universities. In addition, I still conduct night sky programs in several state parks in Texas as well as the Alibates Flint Quarries National Monument near Amarillo, Texas. I have viewed the skies with telescopes from as far north in the U.S. as the Badlands National Park in S.D. and down under in Australia.

The night sky and dark sky conditions at Capulin are excellent. On numerous occasions, over the last several years, I have used a 16 inch Newtonian reflector and a 24 inch at the top of the volcano. Transparency and seeing on those occasions were excellent. The only negative experience was the wind. In addition, several night sky sessions were held below in the picnic area and also the staff housing location for the monument staff. These locations are also dark and excellent for observing. The monument has no lights, other than a few for the staff housing, and these can be easily modified.

Also daytime astronomy events have been conducted during the past two year "Summer Markets. On both events, solar telescopes were utilized for public viewing of sunspots and prominences. Hundreds of visitors were able to experience these live views of the sun.

The Monument staff is planning spring night sky programs. I have volunteered to assist with these as needed.

Overall the Bortle rating of the location would be a 1, I routinely conduct night sky programs at Caprock Canyon State park near Quitaque, Texas which is rated as a 2. Capulin is darker and the altitude is another factor making this location a good candidate for dark sky status.

I strongly endorse Capulin Volcano National Monument be considered for this honor.

Arthur Schneider, Professor Emeritus

Physical Science Department

Amarillo College, Texas

Contributors

Capulin Volcano National Monument Staff:

Edwin Beard - Biological Science Technician
Project lead
edwin_beard@nps.gov

Lynn Cartmell - Lead Park Ranger
Zach Cartmell - Biologist
Randy Bilbeisi - Superintendent

Data Collection and Lighting Mitigations:

Kirsten Schaefer – Seasonal Interpretive Ranger
Teresa Ezersky - Biological Science Technician
Callan Pope – Biological Science Technician
Ty Labeth - Visitor Use and Volunteer Coordinator
Rori Buresh - Seasonal Interpretive Ranger

Night Sky Quality Data and Technical Support Staff:

Randy Stanley - NPS IMR Natural Sounds and Night Skies Coordinator
Teresa Jiles - Research Associate, NPS Natural Sounds & Night Skies Division
Thomas Teters - AstroGraphics Technician, NPS/CIRA/CSU Night Skies Team
Jeremy White - Physical Scientist, NPS Natural Sounds & Night Skies Division

Collaboration and Outreach:

Arthur Schneider - Amarillo College Astronomer
Patricia Walsh – New Mexico State Parks Regional Interpretive Ranger
Robert Bennetts – Southern Plains Network Program Manager
Dita Darrah - David Chandler Company President
Karen Brown - Mandala Center Executive Director
Nathan Ament - Colorado Plateau Dark Sky Cooperative Coordinator

Works Cited

- Beciri, Damir, "Kelvin Scale Color Tone: a definite guide for declaration found on light bulb packages."
- Irwin, Donna. "Night Sky Protection Act Ch. 74 Article 12." New Mexico Legislature, 2009. Web.
- Measuring Lightscares. "Measuring Lightscares." NPS: Explore Nature » Night Skies » Measuring Night Skies. National Park Service, 23 Apr. 2012. Web. 28 Feb. 2016.
- National Weather Service. "AHPS Precipitation Analysis." AHPS Precipitation Analysis. National Oceanic and Atmospheric Administration, 2015. Web. 05 Oct. 2015.
- NPS Night Sky Team. "Interim Outdoor Lighting Guidelines." The American Magazine of Art 25.5 (1932): 292-93. National Park Service, 30 Jan. 2007. Web.
- Saugetierkunde, Zeitschrift fur, "Impacts of artificial lighting on bats: a review of challenges and solutions." Mammalian Biology, 80 (3)

"I like to think the moon is there even if I am not looking at it" - Albert Einstein



Photography by Edwin Beard

Hi John,

As an IDA member in good standing, I am sending this message to formally nominate Capulin Volcano National Monument (CAVO) as an International Dark Sky Park (IDSP). It is my privilege to make this nomination for a number of reasons.

CAVO is a very special place, with unique characteristics that I believe would recommend it in any area of the United States. The 1300 foot volcanic cinder cone makes it a ideal destination for panoramic night sky views and astronomy efforts for many miles in any direction.

I hope you will give CAVO's IDSP application full consideration. In my opinion, IDA's efforts to recognize special dark places like CAVO is critical to gaining public support for night sky protection.

Thank you for your efforts.

Sincerely,

Randy, P.E., PMP, INCE Bd.Cert.



National Park Service | Intermountain Region

Randy Stanley | Natural Sounds & Night Skies Coordinator

Natural Resources Division

12795 W Alameda Pkwy

Lakewood, CO 80228

303-987-6890 phone

Randy_St Stanley@nps.gov
